

Multifunction Network Parameter Meter

RMM-683-02



User Manual

Thank you for choosing the multifunction RMM-683-02 series. This manual will provide you with the detailed steps and precautions regarding Installation, Wiring, Setting of functional parameters, Routine maintenance, Malfunction diagnosis and Solution etc.

To utilize the meter to its full potential and ensure the safety of both users and the product, please read this manual carefully before using the meter. Any incorrect operations may lead to fault, Malfunction or shortened lifetime, or even damage to the device or the people around it.

This manual is available on our website and is accessible through the QR code provided on the unit. We request that you keep it safe considering its importance in commissioning, inspecting, and maintaining the product. In the pursuit of constant improvement, kindly note that all information contained in these materials, including products and product specifications represent information on the product at the time of publication and are subject to change without notice.

1. Introduction	Page No.2
2. Safety recommendations	Page No.6
• Warning	
• Delivery installation	
• Safety guidelines	
• Caution	
3. Installation	Page No.7
• Installation environment	
• Installation guidelines	
4. Feature summary	Page No.8
• Features	
• Salient features	
5. Specification	Page No.10
• Technical specification	
• Accuracy	
• Electrical specification	
• Mechanical specification	
6. Meter overview	Page No.13
• Front panel view	
• Back panel view	
7. Meter panel	Page No.14
• Meter Mounting	
• Meter Demounting	
• IO Module Mounting	
• IO Module Demounting	
• Mechanical Specification	
• Wiring diagram	
• Description of terminals	
8. Display overview	Page No.22
• LCD description	
• Function - LCD symbols, LED description	
9. Key board	Page No.24
• Key description	
• Illustration of keyboard operations	
10. Operating modes	Page No.26
• Measurement mode	
• Configuration mode	
• Diagnostic mode	
• Scrolling mode	
11. Measurement	Page No.38
• Display measured parameter	
• Phase / System Measurement	
• Harmonics overview	
• Min / Max Values	
• Power factor & sign convention	
• Demand measurement	
• Energy - Mains / DG (Import / Export)	
• Terminology	

<ul style="list-style-type: none"> • Voltage Sequence Detection • Current Polarity(CT reversal detection & correction) • Real time clock 	
12. Communication	Page No.47
<ul style="list-style-type: none"> • RS485 • Ethernet 	
13. Multi-tariffs	Page No.53
<ul style="list-style-type: none"> • Command mode overview• Terminology • Time of day mode overview • Input mode overview 	
14. Alarms	Page No.58
<ul style="list-style-type: none"> • Alarms overview • Available alarms • Unary alarms • Available unary alarms • Digital alarms • Standard alarms • Available Standard alarms • Alarm priorities • Alarm setup overview • LED alarm indicator • Alarm History 	
15. Datalogging	Page No.69
16. Inputs/Outputs.....	Page No.74
<ul style="list-style-type: none"> • Available Internal IO ports <ul style="list-style-type: none"> • Digital Input(DI) • Digital Output(DO) • Configuring Internal IO(2DI:2DO) • Available External IO ports <ul style="list-style-type: none"> • Digital Input(DI) • Relay Output(RO) 	
17. Energy Pulsing	Page No.79
<ul style="list-style-type: none"> • Overview • Configuration 	
18. RTD	Page No.79
<ul style="list-style-type: none"> • Overview • RTD Sensor • RTD Connection 	
19. Firmware Update.....	Page No.80

SAFETY

The **RMM-683 SERIES** is a high end multifunction meter series that offers comprehensive 3 phase electrical metering and energy monitoring.

The meter is a panel-mounted 96 x 96 mm panel meter that measures important electrical parameters in 3P4W, 3P3W, and 1P2W L-L and 1P2W L-N networks with field-programmable CT / VT (current transformers/voltage transformers) primary and secondary values.

The meter is easy to install, easy to use, compact in size, and meets all safety and reliability standards. The meter is normally supplied readily pre-programmed for operation and can be directly installed in the usual manner. Meter read/write operations can be performed either manually or through communication protocols, including MODBUS RTU over RS485 and MODBUS TCP over Ethernet.

This user manual describes the basic functions and operational methods of the meter. Please read through this manual carefully before using the product.

Contents of the package:

Unpack the box and check the contents before using the product. If any part or accessory is missing or if the product appears to be damaged, contact our sales representative.

List of accessories

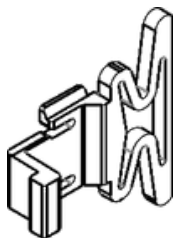
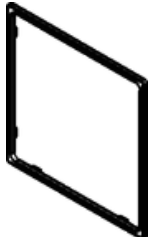
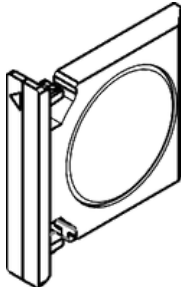
Sr no.	Description of accessories	Image	Qty
1	Panel mount clamp		4
2	Gasket		1
3	Battery holder		1

Read this manual carefully and follow all safety precautions before mounting, installing, operating, and servicing the multifunction meter. Ignoring the safety protocols may cause harm, a loss of life, or damage to property.

Warning

People working on the device should take part in professional electrical and safety training, receive the certification, and be familiar with all steps and requirements of installing, commissioning, operating and maintaining the device to avoid any hazards.

Delivery installation

A pre-delivery inspection for each meter is implemented strictly by our QC department. The packaging is adequately strengthened with special packing materials to protect it from justifiable harm during handling and transportation. However, as an added precaution, we request that you kindly check the following points upon receipt of the device.

- Please check for any damage caused during transportation
- Please check if the enclosed documents are all inside the case, namely the instruction manual and record test certificate
- Please check if this is the model of the product for which you placed an order

Safety guidelines

All safety related codifications, symbols and instructions that appear in this operating manual or on the meter must be strictly followed to ensure the safety of the operating personnel as well as the instrument. If the meter is not used in the manner specified by the manufacturer, it might impair the protection provided by the meter.

Caution

- Do not use the meter if there is any mechanical damage
- Ensure that the equipment is supplied with the correct voltage
- Read the complete instructions prior to the installation and operation of the unit
- The equipment in its installed state must not come in close proximity to any heating sources, oils, steam, caustic vapors, or other unwanted process by products
- Power must be shut of completely before performing any kind of wiring on the auxiliary terminals
- Do not touch the internal components for your own and the product's safety
- Only qualified professional engineers are allowed to assemble, wire, commission or maintain
- Do not conduct the procedure of inspection or maintenance until the meter has been shut down for at least 3 minutes
- No permission is granted to change or modify the internal components or circuits

INSTALLATION

Installation environment

- The surroundings must be free from Dust, Caustic / Corrosive / Inflammable gases / Liquids
- There should not be any metal particulate in the surrounding air
- The ambient temperature should be -10 °C to +55 °C

Installation guidelines

- This equipment, being built-in, normally becomes part of the main control panel
- The terminals do not remain accessible to the end user after installation and internal wiring
- Conductors must not come into contact with the internal circuitry of the meter or else it may lead to a safety hazard that may in turn endanger life or cause an electrical shock to the operator
- A circuit breaker or mains switch must be installed between the power source and supply terminals to facilitate power ON or OFF functions. however, this switch or breaker must be installed in a convenient position that is normally accessible to the operator
- Before disconnecting the secondary of the external current transformer from the equipment, make sure that the current transformer is short circuited to avoid the risk of electric shock and injury
- The equipment does not have a built-in-type fuse; installation of an external fuse of rating 300V 0.5A AC for electrical circuitry.

FEATURES SUMMARY

Features

- LCD display screen.
- True RMS measurement.
- Measurement of 3-phase energy.
- Maximum and minimum of peak, present, predictive and last demand measurements
- Password protected programmable features.
- Pages auto scrolling and manual mode provision.
- Site programmable for CT / VT ratio.
- Site programmable for network selection.
- 33 built-in types of configurable alarms with user-selected priorities.
- User configurable multi-tariff and datalogging.
- External IO modules available: 2DI+4RO
- RS485 MODBUS and Ethernet communication.
- Enclosure protection for dust and water.
- Compliance with the international standard IEC 61557-12 & IEC61326-1.

Salient features

- Accuracy class for active energy (Wh) class 0.2S as per IEC62053-22.
- Accuracy class for reactive energy (VARh) class 1 as per IEC62053-24.
- On site firmware update downloading via the bootloader functionality through ethernet and RS485 communication.
- Endianness selection (MSRF/LSRF).
- Energy auto resolution for Kilo, Mega and Giga values
- Programmable minimum suppression current (2mA to 99mA).
- Power factor sign convention (IEC/IEEE standards).
- Four quadrant measurements of Power Factor & Power.
- Supports data logging up to 30 user-selectable parameters from a total of 105, with a retention period of 90 days at a 5-minute sampling interval.
- 3 Phase Import, Export, Import + Export, Import - Export (Active, Reactive, Apparent) Energies.
- Demand parameters with various methods (Peak, Present, Last, Predictive).
- Time-stamping for the occurrence of Peak demand, Min/Max parameter values (Voltage, Current, Power factor, Power, Frequency) and reset of energies and tariff parameters.
- Measurements of true, Displacement and Distortion power factor.
- Digital input (DI1) for dual energy measurement - Mains and DG.
- Configurable Digital Input(DI2) of 24/48V for external input and demand sync application.
- Configured system error code to define the errors.
- Configurable digital output (DO) for control, synchronization and pulsing application.
- Configurable pulse weight from 1 to 9999999 (pulse/k_h).
- Measurement of motor RPM.
- Real - Time clock (RTC) with 4 and 7 register format.
- RTD (temperature range: -150 to 850 °C).
- THD% , thd% and individual harmonics upto 40th harmonics for voltage & current.
- TDD for calculation of Total demand distortion.
- Crest Factor, K-Factor, CO2 emission.
- Self - Test mode
- 4 tariff with each having 4 time slots settings
- Voltage phase sequence detection
- Current polarity reversal detection and correction
- Load run hour - Based on accumulated energy - Import and Export (mains and DG both), ON hour, Active load timer.
- Number of auxiliary interruptions

SPECIFICATIONS

Technical specifications		
Type of measurement	Networks	3P4W, 3P3W, 1P2W L-N, 1P2W-L-L
		True RMS
Measurement accuracy		Class 0.2S as per IEC62053-22
Display	LCD	Negative (blue) LCD with backlight. 4 line 4 digit: 12.46 x 6.72mm last line of 9 digit: 6.85 x 3.73mm bar graph for % load for each phase
Auxiliary input	Aux voltage	40V - 300V AC/DC
	Power consumption	<10VA
	Freq range	50/60Hz
Measurement input	Input voltage	20 to 277V AC (L-N); 35 to 480V AC (L-L) CAT III 20 to 347V AC (L-N); 35 to 600V AC (L-L) CAT II
	VT secondary	100,110,115,120 V (programmable)
	VT primary	100 V to 999 000 V (programmable)
	Frequency	45 to 65Hz
	Current transformer CT primary	1A / 5A to 32767A (programmable)
	Current transformer CT secondary	1A / 5A (programmable)
	Input current	nominal 5A AC (Min-2mA, Max-8.5A)
	Wire thickness	18-14 AWG (UL)
	Measurement method	True RMS
	Input voltage (Budren)	< 0,2 VA at 300 V AC
	Input current (Budren)	0,5 VA at 5 A
Digital input	DC input	24V/48V DC
Digital output	Digital output	Voltage range: External 48V DC max Current capacity: 20mA max
	Pulse width	1 to 9999999 (pulse per k_h)
	Pulse duration	POP: 50ms For LED: 25ms
	Output type	Open collector RS485
Communication (RS485)	Type	MODBUS RTU
	Baud rate	9600, 19200, 38400, 57600, 115200, bps (programmable)
	Slave ID	1 to 247 (programmable)
	Parity	Odd, Even, None
	Isolation	2 kV AC isolation for 1 minute between communication and other circuits
Communication (ethernet)	Connector	8 pin RJ45
	Speed	10/100 Mbps
	Protocol	TCP (Server, Client), MODBUS TCP
	Standards	IEEE802.3, IEEE802.3u
	Magnetic isolation	1.5KV
	IP configuration	DHCP/Auto IP, Static IP

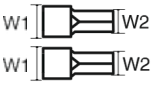
Accuracy	Compliance with the standard	Measurement error
Measurement type	Class of accuracy as per IEC 61557-12 (I _N = 5A-nominal CT)	0.2%
Active energy	Class 0.2S (class 0.2S as per IEC 62053-22 at I _N = 5A nominal CT).	±0.2%
Reactive energy	Class 1 (class 1 as per IEC 620253-24 at I _N 5A nominal CT)	±1%
Apparent energy	Class 0.5S (class 0.5S at I _N = 5A nominal CT)	±0.5%
Active power	±0.2%	
Reactive power	±1%	
Apparent power	±0.5%	
Current	±0.2%	
Voltage (L-L)	±0.2%	
Voltage (L-N)	±0.2%	
Frequency	±0.005 %	
Power factor		
THD and Individual harmonics till 15harmonics	Class 2	±2%
Electrical specification		
Insulation properties	Impulse voltage test	±4kV as per IEC 61010-1
	AC voltage test	±2kV double insulation as per IEC 61010-1
	Insulation resistance	500V DC voltage as per IEC 61010-1
Electrical requirements	Test of power consumption	As per IEC 61010-1
	Voltage dips and Interrupts	As per IEC 61000-4-11
	Short time over current protection	20 times of I _{MAX} for half a second as per IEC 61010-1
Electromagnetic compatibility (EMC)	Electrical fast transient / burst immunity test	IEC 61000-4-4
	Electrostatic discharge immunity test	IEC 61000-4-2
	Radiated, radio-frequency, electromagnetic field immunity test	IEC 6100-4-3
	Immunity to conduct disturbances, induced by radio-frequency fields	IEC 61000-4-6
	Surge immunity test	IEC 61000-4-5
	Rated power frequency magnetic fields	30A/m as per IEC 61000-4-8 for continuous duration 300A/m as per IEC 61000-4-8 for short duration
	Emission	Class A as per CISPR 11
Environmental	Temperature	Operating: -10 °C to 55 °C Storage: -25 °C to 70 °C
	Humidity	Up to 85% non-condensing
Lug dimension		W1 = 4.2mm W2 = 1.8mm W1 = 3.8mm W2 = 1.6mm

Recommended fuse specifications	300V 0.5A AC	
Battery specifications	Coin type lithium battery (CR3032)	3V/220mAh
Mechanical specifications		
Mounting type	Panel mount	
Size	96 x 96mm	
Front bezel	96 x 96mm	
Panel cutout	90.7 x 90.7mm	
Material	Poly carbonate - Lexan 923	
Accessories	Panel mount clamp, Terminal cover	
Weight	350 gm approx.	
Protection rating	IP rating Front: IP65 Back: IP30	
Mechanical testing	Casing plastic mold protected to IP65 from front	
Certification		CE, RoHS

NOTE: Cable size (mm²): 0.75 to 2.5; Tightening torque (Nm): 0.4 to 0.6

METER OVERVIEW

Front panel view



Back panel view

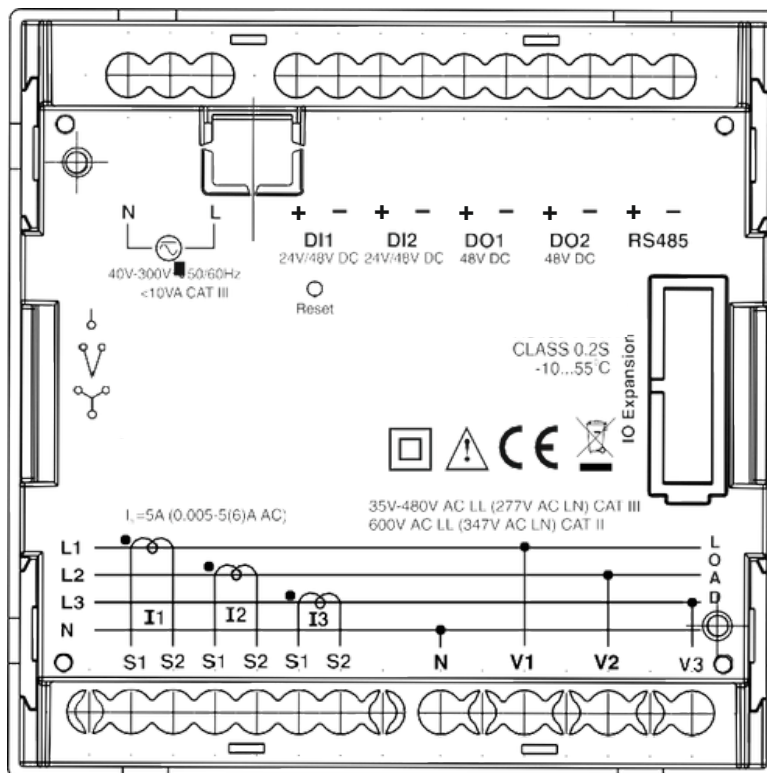

METER PANEL

Mounting

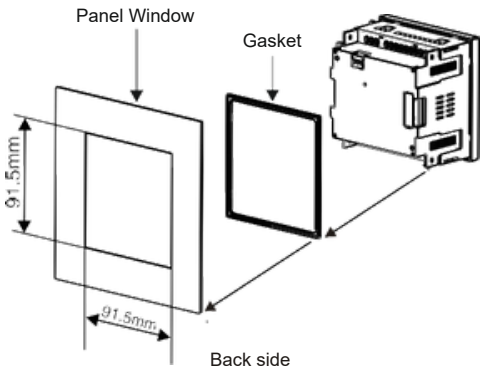
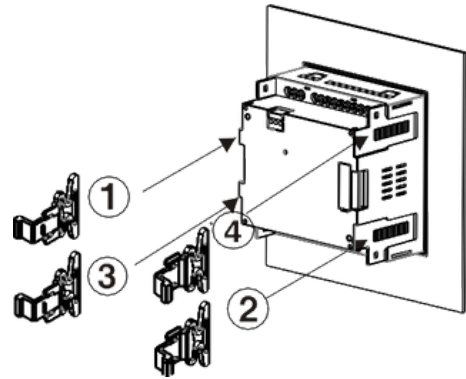
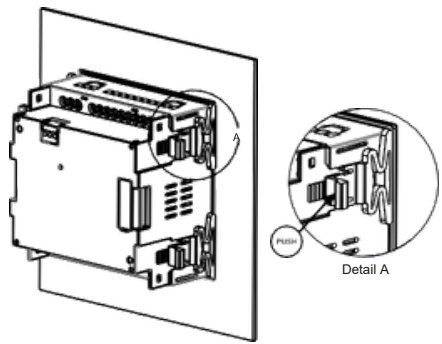
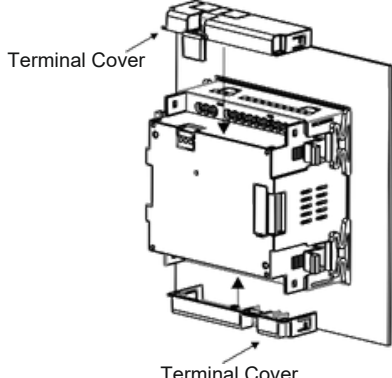
STEP	INSTRUCTION	
1	Prepare the panel cutout with proper dimension as shown below & Insert the meter with gasket into the panel cutout	 <p>Panel Window</p> <p>Gasket</p> <p>91.5mm</p> <p>91.5mm</p> <p>Back side</p>
2	Slide the 4 clamps on both sides of the meter through the clamp slots for optimum fitting, as shown	 <p>1</p> <p>2</p> <p>3</p> <p>4</p>
3	Push the clamps evenly towards the panel until they reach the lowest possible tooth of the slots. Ensure the meter is properly fitted and ready for wiring	 <p>Detail A</p> <p>Push</p>
4	After wiring, place both the terminal covers on the meter	 <p>Terminal Cover</p> <p>Terminal Cover</p>

Demounting

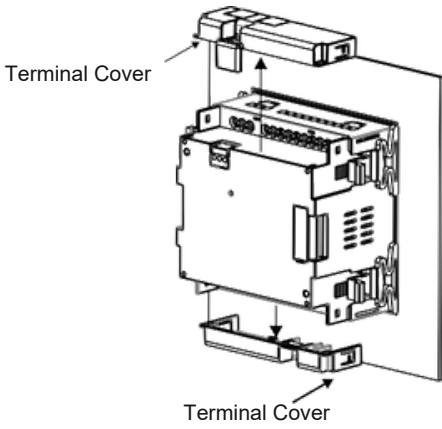
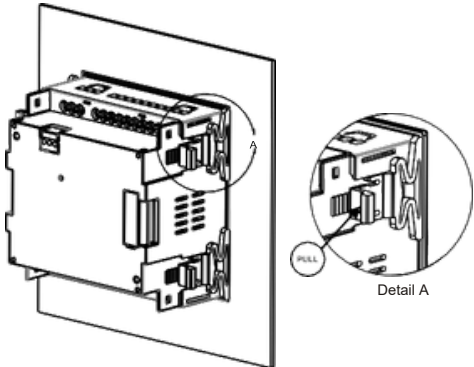
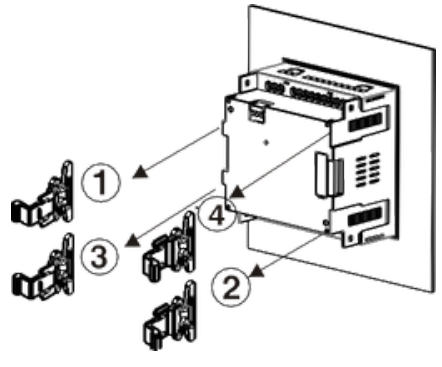
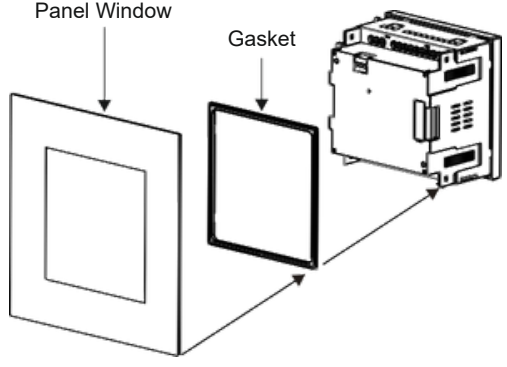
STEP	INSTRUCTION	
1	To demount the unit from panel first remove the terminal covers from the meter	 <p>Terminal Cover</p> <p>Terminal Cover</p>
2	Pull the arm of the sliding clamp in outward direction (opposite to meter) and drag the sliding clamps away from the panel	 <p>Detail A</p> <p>PULL</p>
3	Remove all the 4 clamps from meter	 <p>1</p> <p>2</p> <p>3</p> <p>4</p>
4	Push the meter from the back side of the panel window and remove it from the panel	 <p>Panel Window</p> <p>Gasket</p>

IO Module mounting

Note: To be installed in off condition only

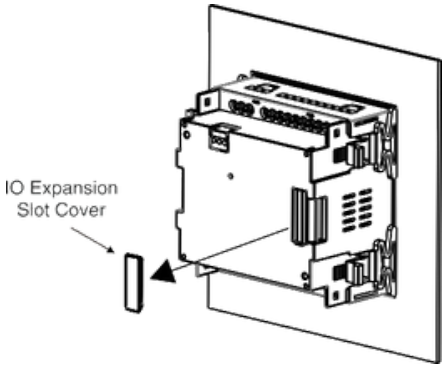
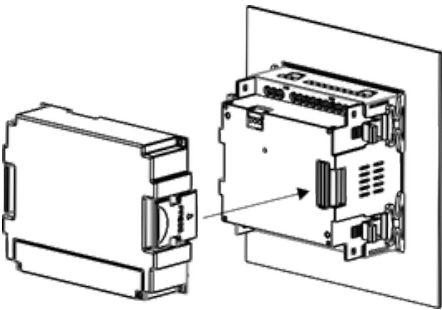
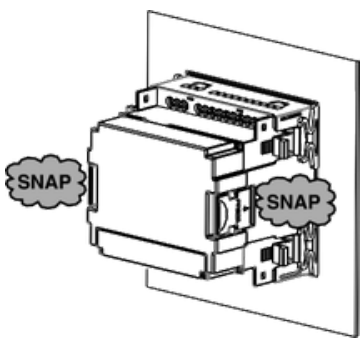
STEP	INSTRUCTION	
1	Remove the IO expansion slot cover from meter	 <p>IO Expansion Slot Cover</p>
2	Plug the IO module into meter as shown	
3	The IO module is secured with the meter after snap sound is heard	

IO MODULE DEMOUNTING

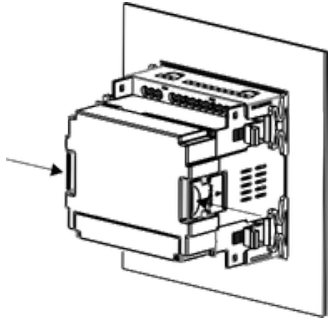
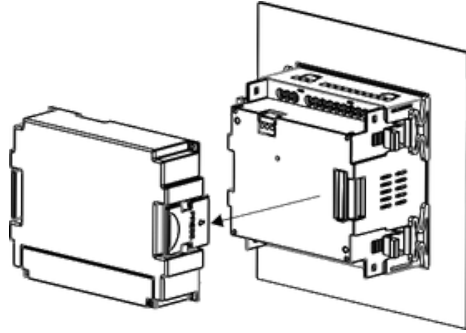
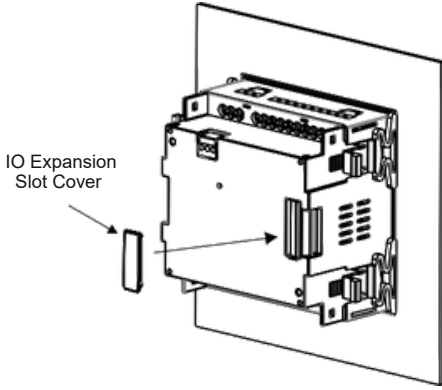
STEP	INSTRUCTION	
1	Pinch the clamps at the specified location to detach the IO expansion module from the meter	 A technical line drawing of an IO expansion module mounted on a meter. An arrow points to the top edge of the module, indicating where to pinch the clamps to detach it from the meter's faceplate.
2	Pull out the IO module	 A technical line drawing showing the IO expansion module being pulled out of its slot on the meter. The module is shown partially detached, with an arrow pointing to the front edge of the module.
3	Put the IO expansion slot cover to the meter	 A technical line drawing of the meter's faceplate with the IO expansion slot cover being placed into the slot. The cover is a small rectangular piece. An arrow points to the cover with the label "IO Expansion Slot Cover".

Mechanical specification

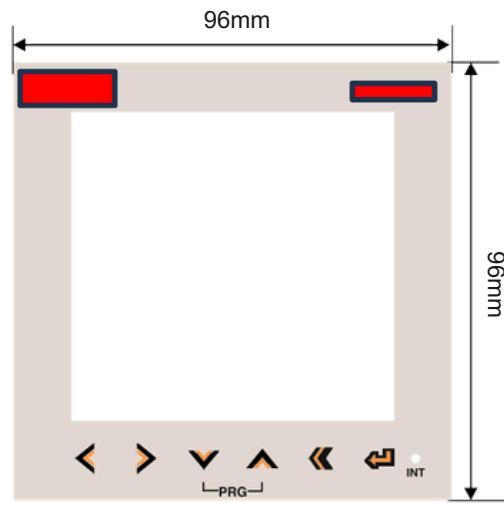

FRONT VIEW

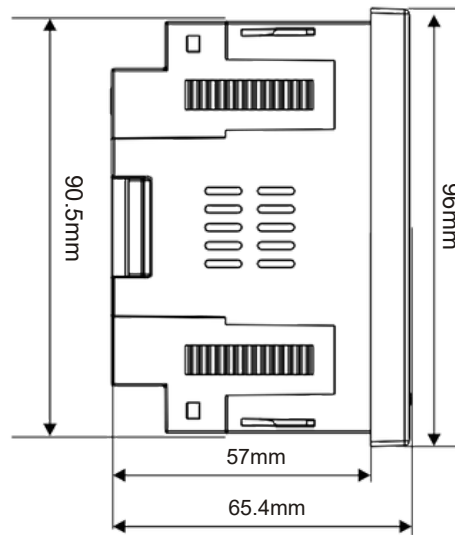

SIDE VIEW

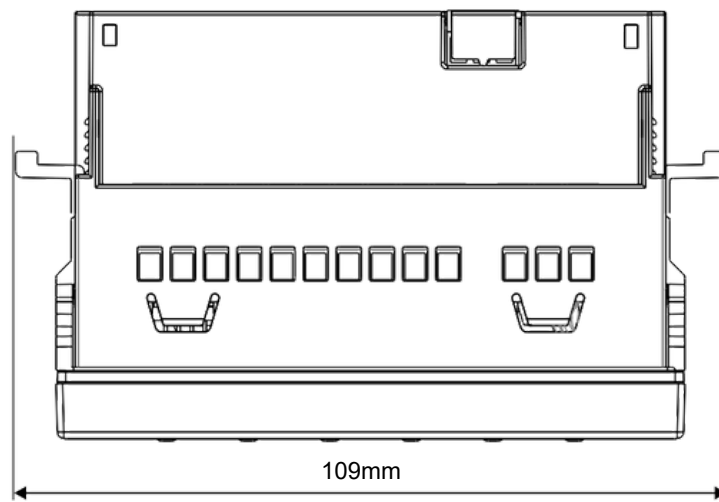

TOP VIEW

Wiring diagram

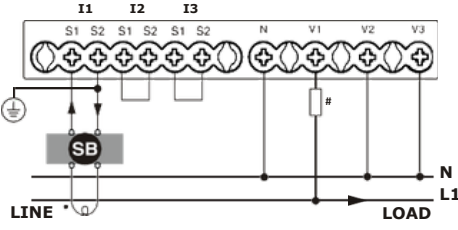
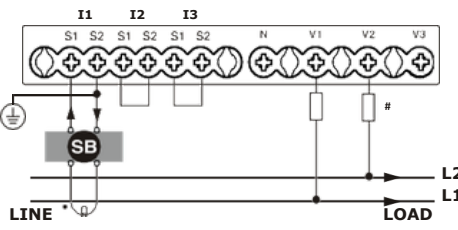
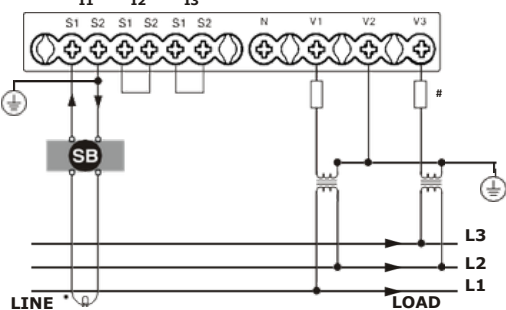
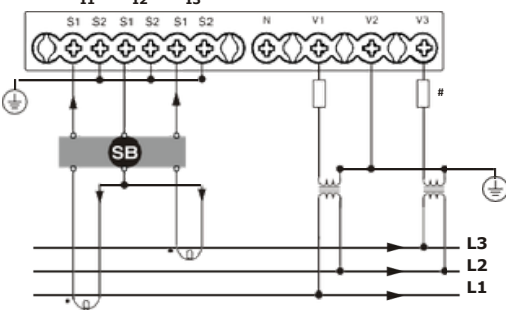
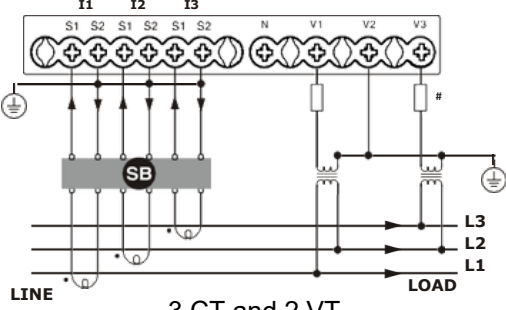
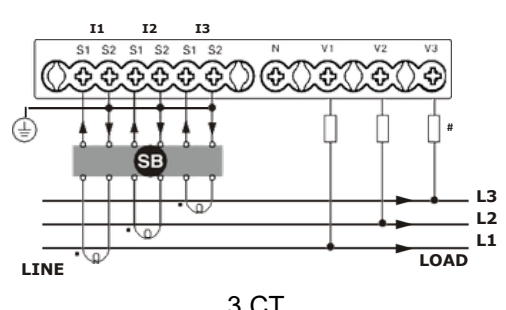
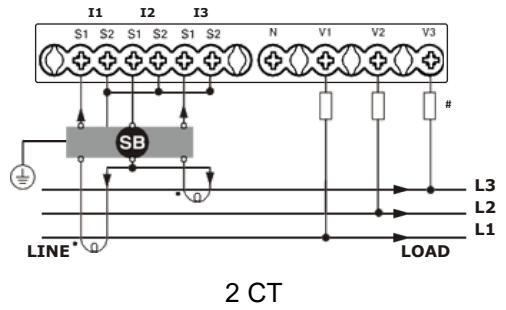
1 PHASE 2 WIRE (L-N)	1 PHASE 2 WIRE (L-L)
 <p style="text-align: center;">1CT (L-N)</p>	 <p style="text-align: center;">1CT (L-L)</p>
3 PHASE 3 WIRE	
 <p style="text-align: center;">1 CT and 2 VT</p>	 <p style="text-align: center;">2 CT and 2 VT</p>
 <p style="text-align: center;">3 CT and 2 VT</p>	 <p style="text-align: center;">3 CT</p>
 <p style="text-align: center;">2 CT</p>	

3 PHASE 4 WIRE

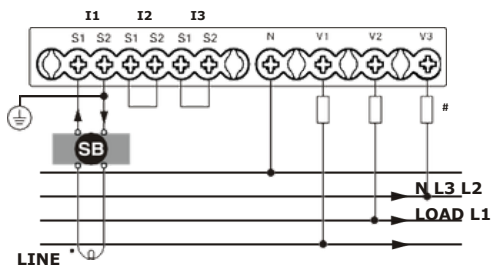

1 CT

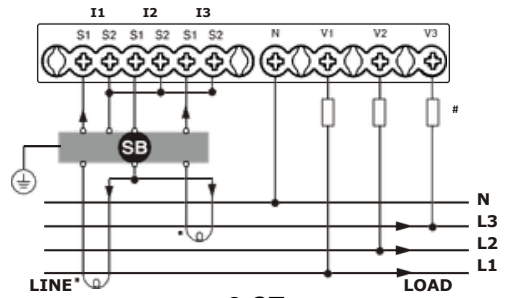

2 CT

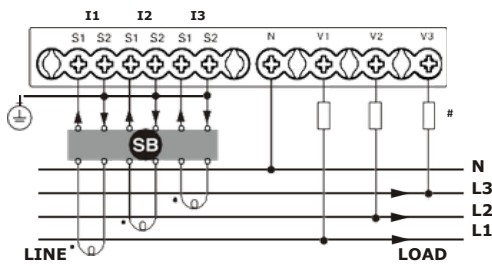

3 CT

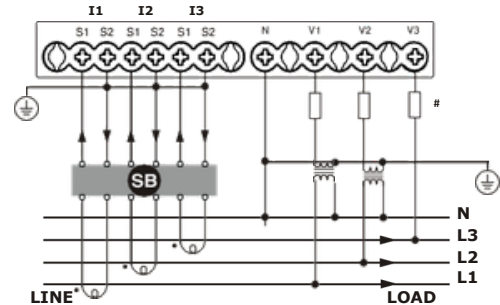

3 CT and 2 VT

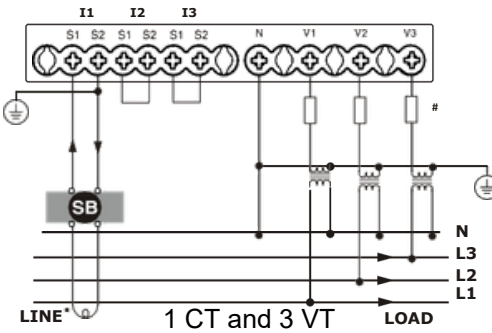

1 CT and 3 VT

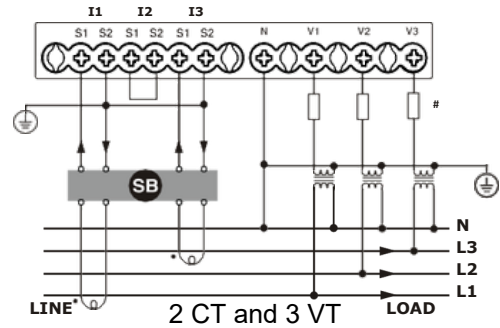

2 CT and 3 VT

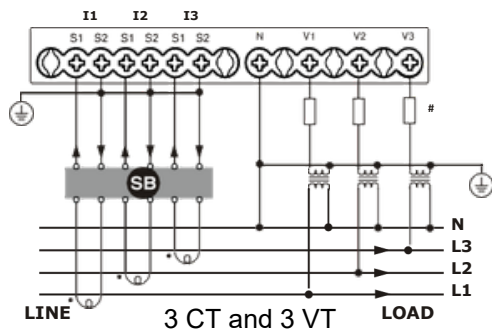

3 CT and 3 VT

Description of terminals

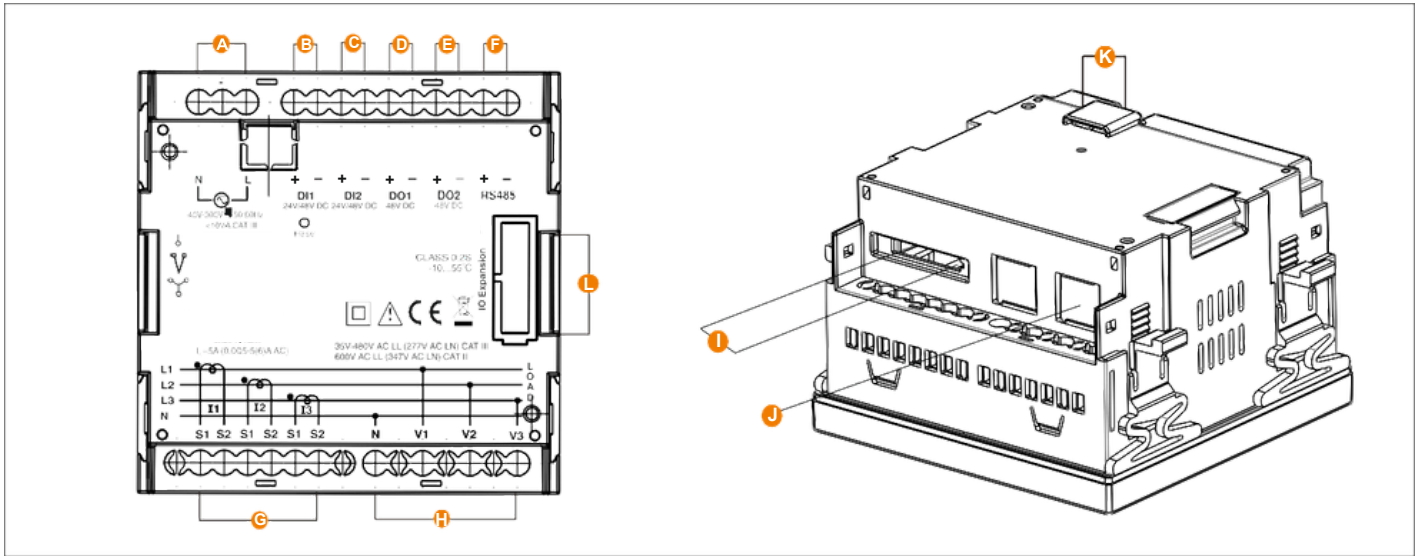

Terminal	Description	
A	L (Line)	Auxiliary input
	N (Neutral)	
B	DI1+	Digital input 1
	DI1-	
C	DI2+	Digital input 2
	DI2-	
D	DO1+	Digital output 1
	DO1-	
E	DO2+	Digital output 2
	DO2-	
F	RS485+	Communication connection
	RS485-	
G	S1(I1)	3 phase current input
	S2(I1)	
	S1(I2)	
	S2(I2)	
	S1(I3)	
	S2(I3)	
H	N (Neutral for voltage input)	Three phase voltage input
	VR (Voltage R - Phase)	
	VY (Voltage Y - Phase)	
	VB (Voltage B - Phase)	
I	RTC BATTERY	RTC
J	ETHERNET	Ethernet
K	RTD1	RTD
	RTD2	
	RTD3	
L	IO expansion	External IO expansion module

DISPLAY OVERVIEW





LCD description:

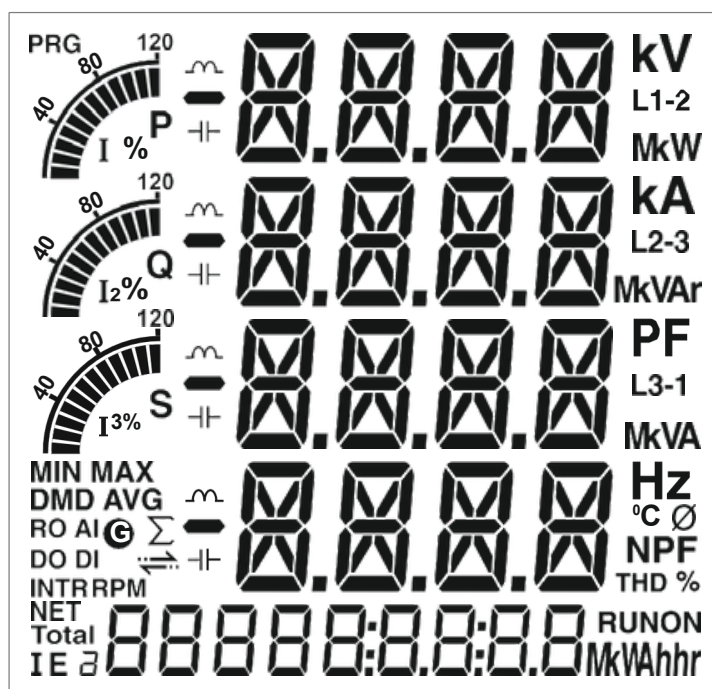

The front of the meter consists of LCD screen and six control keys. All the display segments are illustrated as below.

Function LCD symbols, LED description:

All display segments



Sr. No.	Display	Description
1	 Four lines of 4 digit	The numeric real time metering data will be displayed here
2	 Single line of 9 digit	Display energy data and real time clock (time)
3	kV, kA, PF, Hz, kW, kVAR, kVA, kWh, kVARh, kVAh, k, M	Symbols represents for units representation of parameter values Voltage: V, kV Current: A, kA Active power: kW, MW Reactive power: kVAR, MVAR Apparent power: kVA, MVA Frequency: Hz Active energy: kWh, MWh, kMWh ⁽¹⁾ Reactive energy: kVARh, MVARh, kMVAh ⁽¹⁾ Apparent energy: kVAh, MVAh, kMVAh ⁽¹⁾ For Giga – k and M both symbols will be ON.
4	L1-2, L2-3, L3-1, L _{AVG} , L _N	1, 2, 3: Represents 3 phases 1-2, 2-3, 3-1: Represents 3 phase VLL AVG: represents the average N: Stands for neutral
5	THD%, MIN, MAX, DMD, RPM, 	THD: Total harmonics distortion; MAX: Maximum; MIN: Minimum; DMD: Demand; RPM: Revolution per minute  : Secondary source (DG)

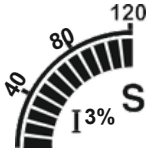





6	∅	Angle symbol
7	$I_{1,2,3}$, $E^{1,2,3}$, Σ	I_{123} : Individual Import energy E^{123} : Individual Export energy Σ : Shows individual summation of powers
8	Total	It shows summation of all 3 import or export energy
9	NET Total	It is absolute summation of total import and total export energy
10	AVG	Used to show average of 3-phase measurable parameter
11		Communication symbol for RS485
12		Load type symbol: Inductive and Capacitive Indicates negative Power & Power factor
13		Bar graph represents percentage load to the rated current for each phase
14	INTR	Auxiliary interrupt
15	ON, RUN	ON hour and RUN hour indications
16	°C	Temperature
17	PRG	Configuration mode
18	P , Q , S	Symbol represent active power, Reactive power and Apparent power respectively

KEYBOARD







Keyboard description

There are 6 dedicated keys to read the meter parameters. Simply press these keys to read the parameters illustrations of keyboard operations with different modes







Key function to access measurement mode parameters

Mode	Key press	Key description
Measurement mode		Phase measurement
		System measurement
		Demand measurement
		Min/Max measurement
		Real time clock
		Energy measurement

Key function to access different features of meter

Mode	Key press	Key description
Measurement mode		Press and hold key for 3 seconds to check the phase voltage sequence detection
		Press and hold key for 3 seconds to check the CT polarity reversal detection
		Press and hold key for 3 seconds to enter or exit from the configuration mode
		Press and hold key for 3 seconds to enter or exit from active alarm list
		Press and hold key for 3 seconds to enter or exit from the self test mode
		Press and hold key for 3 seconds to toggle between automatic and manual (fixed) mode

Key function to access configuration mode parameters





Mode	Key press	Key description
Configuration mode		To move cursor left by one digit each time and to enter in edit mode for parameter value selection
		To move cursor right by one digit each time and to enter in edit mode for parameter value selection
		To decrement the parameter value and also for page change
		To increment the parameter value
		To go back to previous levels
		To save the setting & To enter in the next level

OPERATING MODES





- This meter comes with different types of mode to see the meter features and their functionality. For ease of meter operation, the operating modes are classified as below
- Measurement mode
- Configuration mode
- Self-Test Mode
- Scrolling mode



Measurement mode:

Measurement mode is the default mode when you power up the meter. In measurement mode, the types of measurement have been classified into six specified parameters measurement as mentioned in the table below.

Key press	Key description	Screens	Online page description (3P4W)
	Phase measurements	1	Display V_{LN} of 3 phase and Avg V_{LN} .
		2	Display V_{LL} of 3 phase and Avg V_{LL} .
		3	Display phase current of 3 phase and Avg current.
		4	Display power factor of 3 phase and Avg power factor.
		5	Display phase angle 3 of phase.
		6	Display all 3 phase active power and total active power of 3 phases
		7	Display all 3 phase reactive power and total reactive power of 3 phases.
		8	Display all 3 phase apparent power and total apparent power of 3 phases.
		9	Display V_{LN} THD% of 3 phase and Avg V_{LN} THD%.
		10	Display V_{LL} THD% of 3 phase and Avg V_{LL} THD%.
		11	Display current THD% of 3 phase and Avg current THD%.
	System measurements	1	Display Avg voltage, Current, Power factor and Frequency.
		2	Display 1 st phase voltage, Current, Power factor and Frequency.
		3	Display 2 nd phase voltage, Current, Power factor and Frequency.
		4	Display 3 rd phase voltage, Current power factor and Frequency
		5	Display unbalanced current.
		6	Display neutral current.
		7	Display Total active, Reactive and Apparent power.
	Demand measurements	1	Display peak MAX demand of Active, Reactive and Apparent power.
		2	Display peak MIN demand of Active and Reactive power.
		3	Display present MAX demand of Active, Reactive and Apparent power.
		4	Display present MIN demand of Active and Reactive power.
		5	Display last MAX demand of Active, Reactive and Apparent power.
		6	Display last MIN demand of Active and Reactive power
		7	Display predictive MAX demand of Active, Reactive and Apparent power.
		8	Display predictive MIN demand of Active and Reactive power.
		9	Display peak MAX demand of Avg current.
		10	Display present MAX demand of Avg current.
		11	Display last MAX demand of Avg current.
		12	Display predective MAX demand of Avg current.
	Min / Max measurements	1	Display MAX Avg of Voltage, Current and Frequency
		2	Display MAX Avg V_{LL} .
		3	Display MAX Total of Active, Reactive and Apparent Power.
		4	Display MIN Avg of Voltage, Current and Frequency.
		5	Display MIN Avg V_{LL}
		6	Display MIN Total of Active, Reactive and Apparent Power.
	RTC/ RTD	1	Display Time and Date in RTC
		2	Display RTD Temperature
		3	Display status DI1 and DI2
		4	Display status DO1 and DO2

	Energy measurement	1	Display 1 Phase Import Active Energy
		2	Display 2 Phase Import Active Energy.
		3	Display 3 Phase Import Active Energy.
		4	Display 1 Phase Export Active Energy
		5	Display 2 Phase Export Active Energy.
		6	Display 3 Phase Export Active Energy
		7	Display Total Import Active Energy.
		8	Display Total Export Active Energy
		9	Display NET Total Active Energy
		10	Display 1Phase Import Reactive Energy.
		11	Display 2Phase Import Reactive Energy.
		12	Display 3Phase Import Reactive Energy.
		13	Display 1Phase Export Reactive Energy.
		14	Display 2 Phase Export Reactive Energy.
		15	Display 3Phase Export Reactive Energy.
		16	Display Total Import Reactive Energy.
		17	Display Total Export Reactive Energy.
		18	Display NET Total Reactive Energy
		19	Display 1Phase Import Apparent Energy.
		20	Display 2Phase Import Apparent Energy.
		21	Display 3Phase Import Apparent Energy
		22	Display 1st Phase Export Apparent Energy.
		23	Display 2 Phase Export Apparent Energy.
		24	Display 3phase Export Apparent Energy.
		25	Display Total Import Apparent Energy.
		26	Display Total Export Apparent Energy.
		27	Display NET Total Apparent Energy.
		28	Display RPM

Key Press	Key Description	Screens	Online page description (3P3W)
	Phase measurements	1	Display V_{LL} of 3 phase and Avg V_{LL} .
		2	Display phase current of 3 phase and Avg current.
		3	Display Avg Power Factor.
		4	Display Avg Phase Angle.
		5	Display V_{LL} THD% of 3 phase and Avg V_{LL} THD%.
		6	Display current THD% of 3 phase and Avg current THD%.
	System measurements	1	Display Avg LL VAF and Power Factor.
		2	Display Unbalanced current.
		3	Display Total Active, Reactive and Apparent Power
	Demand measurements	1	Display Peak MAX Demand of Active, Reactive and Apparent Power.
		2	Display Peak MIN Demand of Active and Reactive Power.
		3	Display Present MAX Demand of Active, Reactive and Apparent Power.
		4	Display Present MIN Demand of Active and Reactive Power.
		5	Display Last MAX Demand of Active, Reactive and Apparent Power.
		6	Display Last MIN Demand of Active and Reactive Power.
		7	Display Predictive MAX Demand of Active, Reactive and Apparent Power.
		8	Display Predictive MIN Demand of Active and Reactive Power.
		9	Display Peak MAX Demand of Avg Current.
		10	Display Present MAX Demand of Avg Current.
		11	Display Last MAX Demand of Avg Current.
		12	Display Predictive MAX Demand of Avg Current.
	Min / Max measurements	1	Display MAX Avg LL of VAF .
		2	Display MAX Total of Active, Reactive and Apparent Power.
		3	Display MIN Avg LL of VAF.
		4	Display MIN Total of Active, Reactive and Apparent Power.

	RTC/ RTD	1	Display Time and Date in RTC.
		2	Display RTD Temperature.
		3	Display DI1 and D12
		4	Display DO1 and DO2
	Energy measurement	1	Display Total Import Active Energy
		2	Display Total Export Active Energy.
		3	Display NET Total Active Energy.
		4	Display Total Import Reactive Energy
		5	Display Total Export Reactive Energy
		6	Display NET Total Reactive Energy
		7	Display Total Import Apparent Energy
		8	Display Total Export Apparent Energy
		9	Display NET Total Apparent Energy
		10	Display RPM.

Key Press	Key Description	Screens	Online Page Description (1P2W)
	Phase measurements	1	Display Phase wise Voltage.
		2	Display Phase wise Current.
		3	Display Phase wise Power Factor.
		4	Display Phase wise Phase Angle.
		5	Display Phase wise Voltage THD %.
		6	Display Phase wise Current THD %.
	System measurements	1	Display Phase wise Voltage, Current, Power Factor and Frequency.
		2	Display Active, Reactive and Apparent Power.
	Demand measurements	1	Display Peak MAX Demand of Active, Reactive and Apparent Power.
		2	Display Peak MIN Demand of Active and Reactive Power.
		3	Display Present MAX Demand of Active, Reactive and Apparent Power.
		4	Display Present MIN Demand of Active and Reactive Power.
		5	Display Last MAX Demand of Active, Reactive and Apparent Power.
		6	Display Last MIN Demand of Active and Reactive Power.
		7	Display Predictive MAX Demand of Active, Reactive and Apparent Power.
		8	Display Predictive MIN Demand of Active and Reactive Power.
		9	Display Peak MAX Demand of Current.
		10	Display Present MAX Demand of Current.
		11	Display Last MAX Demand of Current.
		12	Display Predictive MAX Demand of Current.
	Min / Max measurements	1	Display MAX VAF of phase
		2	Display MAX of Active, Reactive and Apparent Power.
		3	Display MIN VAF of phase.
		4	Display MIN of Active, Reactive and Apparent Power.
	RTC/ RTD	1	Display Time and Date in RTC.
		2	.Display RTD Temperature
		3	Display DI1 and D12.
		4	Display DO1 and DO2.
	Energy measurement	1	Display Total Import Active Energy
		2	Display Total Export Active Energy.
		3	Display NET Total Active Energy.
		4	Display Total Import Reactive Energy
		5	Display Total Export Reactive Energy
		6	Display NET Total Reactive Energy
		7	Display Total Import Apparent Energy
		8	Display Total Export Apparent Energy
		9	Display NET Total Apparent Energy
		10	Display RPM.

Key Press	Key Description	Screens	Online Page Description (1P2W-LL)
	Phase measurements	1	Display Phase wise LL Voltage
		2	Display Phase Wise Current
		3	Display Phase Wise Avg Power Angle
		4	Display Phase Wise Avg Power Angle.
		5	Display Phase wise Voltage THD %.
		6	Display Phase wise Current THD %.
	System measurements	1	Display Avg Phase wise Voltage, Current, Power Factor and Frequency.
		2	Display Total Active, Reactive and Apparent Power.
	Demand measurements	1	Display Peak MAX Demand of Active, Reactive and Apparent Power
		2	Display Peak MIN Demand of Active and Reactive Power.
		3	Display Present MAX Demand of Active, Reactive and Apparent Power.
		4	Display Present MIN Demand of Active and Reactive Power.
		5	Display Last MAX Demand of Active, Reactive and Apparent Power.
		6	Display Last MIN Demand of Active and Reactive Power.
		7	Display Predictive MAX Demand of Active, Reactive and Apparent Power.
		8	Display Predictive MIN Demand of Active and Reactive Power.
		9	Display Peak MAX Demand of Current.
		10	Display Present MAX Demand of Current.
		11	Display Last MAX Demand of Current.
		12	Display Predictive MAX Demand of Current.
	Min / Max measurements	1	Display MAX Average LL of VAF.
		2	Display MAX total of Active, Reactive and Apparent Power.
		3	Display MIN Average LL of VAF.
		4	Display MIN total of Active, Reactive and Apparent Power.
	RTC/ RTD	1	Display Time and Date in RTC.
		2	Display RTD Temperature.
		3	Display D11 and D12.
		4	Display DO1 and DO2.
	Energy measurement	1	Display Total Import Active Energy
		2	Display Total Export Active Energy.
		3	Display NET Total Active Energy.
		4	Display Total Import Reactive Energy
		5	Display Total Export Reactive Energy
		6	Display NET Total Reactive Energy
		7	Display Total Import Apparent Energy
		8	Display Total Export Apparent Energy
		9	Display NET Total Apparent Energy
		10	Display RPM.

Configuration mode:

The configuration mode allows the user to configure the functions. The functions are explained in the table below.

Note: The settings should be done by a professional, after going through this user's manual and after having understood the application situation.

Time out for configuration mode is 1 minute. After time out, meter exits configuration mode and goes measurement mode.

- Basic Setup
- Power Demand
- Current Demand
- Energy
- Serial Communication
- RTC
- Alarm
- Internal IO
- Factory Default
- Reset Parameters.

Configuration mode:

Level 1	Level 2	Level 3	Range or Selection	Default value	Remark
Change password	New password		0000 to 9998	1000	
Basic	Network Selection		3F4P, 3F3P, 1F2P L-N, 1F2P-L-L	3P4W	
	CT Terminal Selection		CT1 CT2 CT3 CT12 CT23 CT31 CT123 NONE	NONE	NOTE: The CT terminal parameters are enabled based on the selected network and VT connect configuration
	CT Secondary		1 or 5	5	
	CT Primary		1 or 5 to 32767	5	
	VT Connection Selection		NO VT 1 VT 2 VT 3 VT	NO VT	NOTE: The VT connect parameters are enabled based on selected network
	VT Secondary		100 110 115 120	100	NOTE: VT primary will not be enabled if VT selection is NO VT
	VT Primary		100 to 1000000	100	NOTE: VT secondary will not be enabled if VT connect is NO VT
	System Frequency Selection(Hz)		50/60	50	
	Minimum Suppression Current(mA)		2 to 99 mA	11 mA	
	LOAD I TIMER SET POINT		5 to 50000 mA	11 mA	
	CT Sequence		CT123 CT321 CT312 CT231 CT213 CT132	CT123	NOTE: The CT sequence is applicable for 3P3W and 3P4W configurations and CT123 CT terminal value. If you change the network or CT terminal value, then the CT sequence resets to the default value.
	CT POLARITY		CT1 CT2 CT3 CT12 CT23 CT31 CT123 NONE	NONE	NOTE: The CT polarity parameters are enabled based on selected network and CT terminal value. If you change the network or CT terminal value, then the CT polarity correction resets to the default value.
	NUMBER OF POLE SELECT (EVEN NUMBER)		02 to 98	2	
	PF CONVENTION SELECTION		IEC IEEE	IEC	

Power & Current	DMD method		Sliding, Fixed, Fixed-Sliding, Thermal	Sliding		
	DMD duration (min)		1 to 60	15		
	DMD length (min)		1 to 60	1		
	Demand sync type		None, Command, Clock-sync, Input	None		
	Demand clock sync time	Clock sync hour		0 to 23	0	NOTE: Demand Clock Sync time option is only available if in Demand sync type Clock-Sync is selected
		Clock sync minute		0 to 59	0	
		Clock sync second		0 to 59	0	
	Digital output selection		NONE, DO1, DO2	NONE	NOTE: The digital output selection is only available if Demand Sync type is selected as input.	
Digital input selection		NONE & DI2	NONE	NOTE: The digital output selection is only available if Demand Sync type is selected as input.		
Energy	POP 1 ENERGY		NONE IMPORT kWh EXPORT kWh TOTAL kWh IMPORT kVARh EXPORT kVARh TOTAL kVARh IMPORT kVAh EXPORT kVAh TOTAL kVAh	NONE		
	POP1 pulse width		1 to 9999999	1000		
	POP 2 energy		NONE IMPORT kWh EXPORT kWh TOTAL kWh IMPORT kVARh EXPORT kVARh TOTAL kVARh IMPORT kVAh EXPORT kVAh TOTAL kVAh	NONE		
	POP2 pulse width		1 to 9999999	1000		
	LED CTRL mode		NONE/ ALARM /ENERGY	NONE		
	LED energy		NONE IMPORT kWh EXPORT kWh TOTAL kWh IMPORT kVARh EXPORT kVARh TOTAL kVARh IMPORT kVAh EXPORT kVAh TOTAL kVAh	NONE	NOTE: These parameters are only visible if selected LED mode as energy & LED Pulse width is configured.	
	LED pulse width		1 to 9999999	1000		
	Serial Communication	Communication password		0 to 9999	1000	NOTE: Password same as configuration password
Change communication password			NO, YES	NO		
Communication setting			ON, OFF	ON		
Slave ID selection			1 to 247	1		
Baudrate selection			9600/ 19200/ 38400/ 57600/ 115200	9600		

COMMUNICATION	Parity selection		NONE/ODD/EVEN	NONE	
	Stopbit selection		1 or 2	1	
	Endianness		MSRF/LSRF	MSRF	Note: This parameter will help you see values in LSRF (Mid-Little endian) or MSRF (Big endian)
HMI & CLOCK	Backlight off timer (secs)		0 to 7200	0	
	SET RTC Date	SET RTC YEAR	24 to 90	85	
		SET RTC MONTH	1 to 12	12	
		SET RTC DAY	1 to 31	1	
		SET RTC Week Day	SUNDAY MONDAY TUESDAY WEDNESDAY THURSDAY FRIDAY SATURDAY	MONDAY	
	SET RTC Time	SET RTC HOUR	0 to 23	0	
		SET RTC MIN	0 to 59	0	
SET RTC SEC		0 to 59	0		
Alarms	Current alarms	Alarm selection	Over Current Phase, Under Current Phase, Over Current Neutral	OVER CURRENT PHASE	
		Enable	OFF, ON	OFF	
		Pickup set point	00.0000 to 10.0000	0.0000	
		Pickup time delay (s)	0 to 999999	0	
		Dropout setpoint	00.0000 to 10.0000	0.0000	
		Dropout time delay (sec)	0 to 999999	0	
		Priority	NONE, LOW, MEDIUM, HIGH	NONE	
	Digital output selection	NONE, DO1, DO2	NONE	NOTE: The digital output selection is available only if control mode is set to ALARM	
	Relay output selection	NONE (EXTERNAL)RO1 (EXTERNAL)RO2 (EXTERNAL)RO3 (EXTERNAL)RO4	NONE	NOTE: The Relay output selection will be available only if control mode is set to ALARM. * It is only configurable through MODBUS.	
	Voltage alarms	Alarm selection	Over Voltage L-L, Under Voltage L-L, Over Voltage L-N, Under Voltage L-N, Over Voltage Unbal, Over Voltage THD, Phase Loss	OVER VOLTAGE L-L	
Enable		YES/NO	NO		
Pickup set point		000.00 to 600.00(V-LL), 000.00 to 347.00(V-LN), 0.00 to 100.00 (V-unbal, THD)	000.00		
Pickup time delay (s)		0 to 999999	0		

Alarms	Voltage Alarms	Dropout setpoint	000.00 to 600.00(V-L), 000.00 to 347.00(V-LN), 0.00 to 100.00 (V-unbal, THD)	000.000	
		Dropout time delay (sec)	0 to 999999	0	
		Priority	NONE, LOW, MEDIUM, HIGH	NONE	
		Digital output selection	NONE, DO1, DO2	NONE	NOTE: The digital output selection is available only if control mode is set to ALARM
		Relay output selection	NONE (EXTERNAL)RO1 (EXTERNAL)RO2 (EXTERNAL)RO3 (EXTERNAL)RO4	NONE	NOTE: The Relay output selection will be available only if control mode is set to ALARM. * It is only configurable through MODBUS.
	Power Alarms	Alarm selection	OVER ACTIVE, OVER REACTIVE, OVER APPARANT	OVER ACTIVE	
		Enable	OFF & ON	OFF	
		Pickup set point	00000.000 to 10410.000	00000.000	
		Pickup time delay (s)	0 to 999999	0	
		Dropout setpoint	00000.000 to 10410.000	0	
		Dropout time delay (s)	0 to 999999	0	
		Priority	NONE, LOW, MEDIUM, HIGH	NONE	
		Digital output selection	NONE, DO1, DO2	NONE	NOTE: The digital output selection is available only if control mode is set to ALARM
Relay output selection	NONE (EXTERNAL)RO1 (EXTERNAL)RO2 (EXTERNAL)RO3 (EXTERNAL)RO4	NONE	NOTE: The Relay output selection will be available only if control mode is set to ALARM. * It is only configurable through MODBUS.		
	Demand Alarms	Alarms selection	OVER ACTIVE PRESENT, OVER ACTIVE LAST, OVER ACTIVE PREDICTIVE, OVER REACTIVE PRESENT, OVER REACTIVE LAST, OVER REACTIVE PREDICTIVE, OVER APPARANT PRESENT, OVER APPARANT LAST, OVER APPARANT PREDICTIVE	OVER ACTIVE PRESENT	

	Demand Alarms	Enable	YES/NO	NO	
		Pickup set point	00000.000 to 10410.000	00000.000	
		Pickup time delay (s)	0 to 999999	0	
		Dropout setpoint	00000.000 to 10410.000	00000.000	
		Dropout time delay (s)	0 to 999999	0	
		Priority	NONE, LOW, MEDIUM, HIGH	NONE	
		Digital output selection	NONE, DO1, DO2	NONE	NOTE: The digital output selection is available only if control mode is set to ALARM
		Relay output selection	NONE (EXTERNAL)RO1 (EXTERNAL)RO2 (EXTERNAL)RO3 (EXTERNAL)RO4	NONE	NOTE: The Relay output selection will be available only if control mode is set to ALARM. * It is only configurable through MODBUS.
	Frequency Alarms	Alarm selection	OVER FREQUENCY, UNDER FREQUENCY	OVER FREQUENCY	
		Enable	OFF & ON	OFF	
		Pickup set Point	45.000 to 65.000	0	
		Pickup time delay (s)	0 to 999999	0	
		Dropout setpoint	45.000 to 65.000	0	
		Dropout time delay (s)	0 to 999999	0	
		Priority	NONE, LOW, MEDIUM, HIGH	NONE	
		Digital output selection	NONE, DO1, DO2	NONE	NOTE: The digital output selection is available only if control mode is set to ALARM
Relay output selection	NONE (EXTERNAL)RO1 (EXTERNAL)RO2 (EXTERNAL)RO3 (EXTERNAL)RO4	NONE	NOTE: The Relay output selection will be available only if control mode is set to ALARM. * It is only configurable through MODBUS.		
	RTD * Alarms	Alarm selection	OVER RTD, UNDER RTD	OVER RTD	
		Enable	OFF & ON	OFF	
		Pickup (celsius)	-170.0 to 850.0	0	
		Pickup time delay (s)	0 to 999999	0	
		Dropout (celsius)	-170.0 to 850.0	0	
		Dropout time delay (s)	0 to 999999	0	
		Priority	NONE, LOW, MEDIUM, HIGH	NONE	
Digital output selection	NONE, DO1, DO2	NONE	NOTE: The digital output selection is available only if control mode is set to ALARM		

	RTD Alarms	Relay output selection	NONE (EXTERNAL)RO1 (EXTERNAL)RO2 (EXTERNAL)RO3 (EXTERNAL)RO4	NONE	NOTE: The Relay output selection will be available only if control mode is set to ALARM. * It is only configurable through MODBUS.
	PF * Alarms	Alarm selection	TRUE PF, DISPLACEMENT PF	-	
		Enable	OFF & ON	OFF	
		Pickup setpoint	-1.0000 to 1.0000	0	
		Pickup time delay (s)	0 to 999999	0	
		Dropout setpoint	-1.0000 to 1.0000	0	
		Dropout time delay (s)	0 to 999999	0	
		Priority	NONE, LOW, MEDIUM, HIGH	NONE	
		Digital output selection	NONE, DO1, DO2	NONE	NOTE: The digital output selection is available only if control mode is set to ALARM
		Relay output selection	NONE (EXTERNAL)RO1 (EXTERNAL)RO2 (EXTERNAL)RO3 (EXTERNAL)RO4	NONE	NOTE: The Relay output selection will be available only if control mode is set to ALARM. * It is only configurable through MODBUS.
		PICKUP PF TYPE	NONE INDUCTIVE CAPACITIVE	NONE	
		DROPOUT PF TYPE	NONE INDUCTIVE CAPACITIVE	NONE	
Internal IO	DI2 Control Mode	NONE, NORMAL, DEMAND SYNC	NONE		
	DI2 Debounce Time	10 to 9999ms	10		
	DO1 Control Mode	NONE, ENERGY PULSES, EXTERNAL, DEMAND, ALARM	NONE		
	DO2 Control Mode	NONE, ENERGY PULSES, EXTERNAL, DEMAND, ALARM	NONE		
FACTORY DEFAULT		YES/NO	NO		

Reset Parameter	Reset Password	0 to 9999	0	
	Reset meter Parameter	Yes/No	No	
	Reset Active Energy	None, Mains, DG, Both	None	
	Reset Reactive Energy	None, Mains, DG, Both	None	
	Reset Apparent Energy	None, Mains, DG, Both	None	
	Reset Max Demand	None, Power Demand, Current Demand, Both	None	
	Reset Run Hour	Yes/No	No	
	Reset On Hour	Yes/No	No	
	Reset Load Timer	Yes/No	No	
	Reset Auxiliary Interupt	Yes/No	No	
	Reset Min/Max	Yes/No	No	
	Reset Alarm Counter	Yes/No	No	
	Reset IO Counter	Yes/No	No	
	Reset Tariff	Yes/No	No	

*Note: Configurable only through Utility. Fixed tariff will not be reset in any of the case.

Configuration mode password

For setting the configuration mode parameters user will be prompted for the password. If correct password is entered, user will be able to access the all programming parameters.

Description	Range	
Configuration mode	0000-9997	Default: 1000
Communication	0001-9998	This password will be greater than the configuration password by 1 i.e. (1001)

Self-Test mode:

The meter offers in built self-test mode feature to identify the meter's measurement failure and communication failure error with meter's system information given in table below.

Sr. No.	Function	Description
1	All segment and LED ON	On entering self-test mode, all LCD segments will be ON
2	Serial number	Displays the meter serial number, for example 50220001
3	Hardware version	Displays the meter hardware version number
4	Software version	Displays the meter software version number
5	Boot loader version	Displays the meter boot loader version number

6	System error code	<p>Displays the system error codes of the meter and are mentioned in hex code.</p> <p>Note: If more than one error occur, then the display will show summation of those errors.</p>
7	ON hour	Indicates the period for which the power meter's auxiliary supply is ON, regardless of the voltage and current inputs.
8	Run hour	Indicates the period when the average current is present.
9	Import run hours - mains	Indicates the period the load has been delivered. This counter accumulates as long as the load is ON.
10	Export run hours - mains	Indicates the period the load has been received. This counter accumulates as long as the load is ON
11	Import run hours - DG	Indicates the period the load has been delivered. This counter accumulates as long as the generator load is ON.
12	Export run hours - DG	Indicates the period the load has been received. This counter accumulates as long as the generator load is ON.
13	Load run hr	The system allows the configuration of a threshold value for the current. When the measured current is equal to or exceeds this configured threshold, the associated time duration will in crese. Indicates number of times meter was turned OFF & ON.
14	Auxiliary interruption	
15	Communication error	
16	External IO	Indicates type of IO card connected to the meter. 2400 represents 2DI-4RO card is connected

Scrolling mode:

The user can set the display screen in auto scrolling mode or manual screen mode via the front panel keys.

Long press  for 3 seconds to toggle between manual and automatic mode.

- Automatic mode: In automatic mode, Online pages scroll automatically at a rate of 5 seconds per page. In automatic mode, when any key is pressed, the unit temporarily switches to manual mode and the appropriate page is displayed. Also, if any key is not pressed for 5 seconds, unit resumes automatic mode. The RTC page will not be visible while scrolling but can be viewed if the key is pressed.
- Manual mode: In manual mode, selected online page will remains static.

MEASUREMENTS

Display measured parameter

Function	Description	Parameters	
Real time measuring	VL-N phase voltage per phase and 3 phase average	V1, V2, V3, VLNAVG	
	VL-L line voltage per phase and 3 phase average	V12, V23, V31, VLLAVG	
	Current - per phase and 3 phase average	I1, I2, I3, IAVG	
	Calculated neutral current	IN	
	Unbalanced voltage *	V1, V2, V3, V12, V23, V31, VLN _{VG} , VLL _{AVG} VLN _{WORST} , VLL _{WORST}	
	Unbalanced current *	I1, I2, I3, IAVG, IWORST	
	Worst Current	IWORST	
	Active power	KW1, KW2, KW3, KWTOTAL	
	Reactive power	KVAR1, KVAR2, KVAR3, KVAR _{TOTAL}	
	Apparent power	KVA1, KVA2, KVA3, kVATOTAL	
	Phase angle	PA1, PA2, PA3	
	True power factor - per phase and 3 phase average	PF1, PF2, PF3, PFAVG	
	Displacement power factor - per phase and 3 phase average *	PF1, PF2, PF3, PFAVG	
	Distortion power factor - per phase and 3 phase average*	PF1, PF2, PF3, PFAVG	
	Frequency	Hz	
	THD VL-N %	V1, V2, V3, VLNAVG	
	THD VL-L %	V12, V23, V31, VLLAVG	
	THD current %	I1, I2, I3, IN, IAVG	
	thd VL-N%	V1, V2, V3, VLNAVG	
	thd VL-L%	V12, V23, V31, VLLAVG	
thd current	I1, I2, I3, IAVG		
Min and Max values with time stamping*	Average voltage L-N	VLNMIN, VLNMAX ,	
	Average voltage L-L	VLLMAX, VLLMIN	
	Current	IMIN, IMAX	
	Neutral current *	INMAX, INMIN	
	PF *	PF1MIN, PF1MAX PF2MIN, PF2MAX PF3MIN, PF3MAX	
	Total power	KWMIN, KWMAX KVAMIN, KVAMAX KVARMIN, KVARMAX	
	Frequency	HzMIN, HzMAX	
Demand	Power demand	Max(KW,KVA,KVAR)	Last demand Present demand Predictive demand Peak demand
		Min(KW,KVAR)	
	Current demand (I1,I2,I3,I ^{VG})		Last demand Present demand Predictive demand Peak demand

Energy (mains)	Active energy Apparent energy Reactive energy (4 quadrant based VARh *)	Accumulated energy Import - per phase and total Export - per phase and total Total NET (Import + Export) Total NET (Import - Export) *
		Last cleared energy * Import - per phase and total Export - per phase and total Total NET (Import + Export) Total NET (Import - Export)
Energy (DG)	Active energy Apparent energy Reactive energy	Accumulated energy Import - Per phase and total Export - Per phase and total Total NET (Import + Export) Total NET (Import-Export) *
		Last cleared energy * Import - per phase and total Export - per phase and total Total NET (Import + Export) Total NET (Import - Export)
RTC	Date and Time	DD:MM:YY HH:MM:SS
RPM	Revolution per minute	RPM
ON HR	ON Hour	Hour
Run hours	Run hour: Import/Export - Mains	Import run Hours - Mains
		Export run Hours - Mains
	Run hour: Import/Export - DG	Import run Hours - DG
		Export run Hours - DG
Load Run Hour	Load Run Hour	Hour
AUX Interruption	Auxiliary interrupts	

Note: DG (RMM's meter) Energy are only displayed when DG is connect to DI 1.

All features can be accessed via communication or from the meter front, however * indicating features that can only be accessed via communication.

Phase and system measurement:

The meter provides highly accurate 1-second measurements, Average values, Including true RMS, Per phase and total.

- Per phase and average voltage (line-to-line, line-to-neutral)
- Per phase and average current, and neutral current (neutral current is calculated)
- Per phase and total power (VA, W, Var)
- Per phase and average for true and displacement power factor
- System frequency
- Per phase and maximum of all three for voltage unbalance and current unbalance

Harmonics overview:

Harmonics, integer multiples of the fundamental frequency, are a common power quality issue that can significantly impact the performance and reliability of electrical systems. They arise from non-linear loads, such as electronic devices, variable speed drives, and arc furnaces, which draw non-sinusoidal current. The presence of harmonics can lead to a variety of problems, including increased power losses, equipment overheating, voltage distortion, and interference with communication systems. To mitigate these issues, it's crucial to monitor and analyze harmonic levels in power systems. By understanding the sources and impacts of harmonics, engineers can implement appropriate mitigation strategies, such as harmonic filters, to ensure the overall quality and efficiency of the power system.

Total harmonics distortion %:

Meter can measure and analyze several power quality parameters which is useful for further analyzing the voltage and current signals measured by the meter. Total Harmonic Distortion: A ratio of the sum of powers in all harmonic components to power of the fundamental frequency. Meter also supports even and odd order THD, where even order harmonics are the 2nd, 4th, 6th, and so on and odd order harmonics are 3rd, 5th, 7th, etc. %THD of voltage and current per phase and average value data can be accessed via communication or from the meter front, however individual harmonics can only be accessed via communication.

Total demand distortion:

Total demand distortion (TDD) is a crucial metric in power systems that quantifies the impact of harmonic currents on the system's capacity. It's a more accurate measure of harmonic distortion than Total Harmonic Distortion (THD) because it considers the system's full load current.

Harmonic content calculations:

Harmonic content (HC) is equal to the RMS value of all the non-fundamental harmonic components in one phase of the power system. The meter uses the following equation to calculate HC:

$$HC = \sqrt{(H_2)^2 + (H_3)^2 + (H_4)^2 + \dots}$$

THD% calculations:

THD% is a quick measure of the total distortion present in a waveform and is the ratio of harmonic content (HC) to the fundamental harmonic (H1). By default, the meter uses the following equation to calculate THD%:

$$THD = (HC/H_1) \times 100\%$$

thd% calculations:

thd% is an alternate method for calculating total harmonic distortion that uses the RMS value for the total harmonic content rather than the fundamental content. The meter uses the following equation to calculate thd:

$$thd = (HC / \sqrt{(H_1)^2 + (HC)^2}) \times 100\%$$

TDD calculations:

TDD (total demand distortion) evaluates the harmonic currents between an end user and a power source. The harmonic values are based on a point of common coupling (PCC), which is a common point where each user receives power from the power source. The meter uses the following equation to calculate TDD:

$$TDD = (\sqrt{(HC)_a^2 + (HC)_b^2 + (HC)_c^2}) / (I_{Load}) \times 100\%$$

Where I_{Load} is equal to the maximum demand load on the power system.

Min/Max values:

The meter logs maximum and minimum value for real time as well as the time when they occurred. All data is stored in non-volatile memory so that statistic information can be preserved even when the meter loses power or gets shut off. All maximum and minimum data of V_{LN} , V_{LL} , Current, Total power and Frequency can be accessed via communication or from the meter front. However only power factor's Min/Max value can only be accessed via communication.

Power factor & sign convention

Power factor sign (PF sign) can be positive or negative, and is defined by the conventions used by the IEEE or IEC standards. You can set the power factor sign (PF sign) convention that is used on the display to either IEC or IEEE.

• PF sign convention: IEC

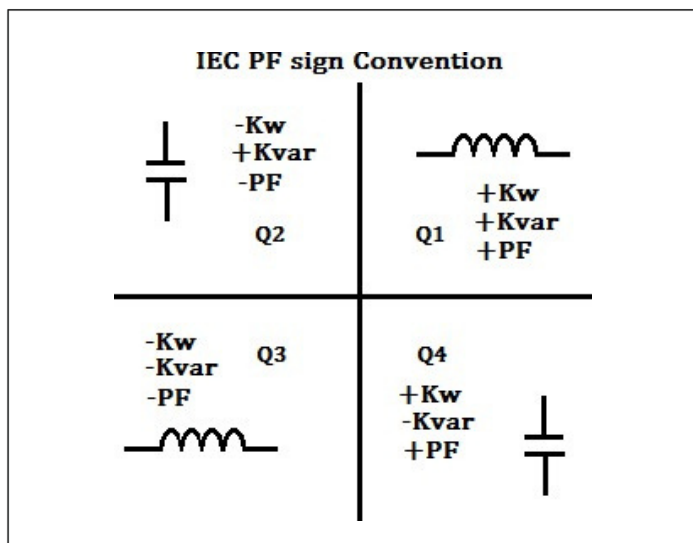

• PF sign convention: IEEE

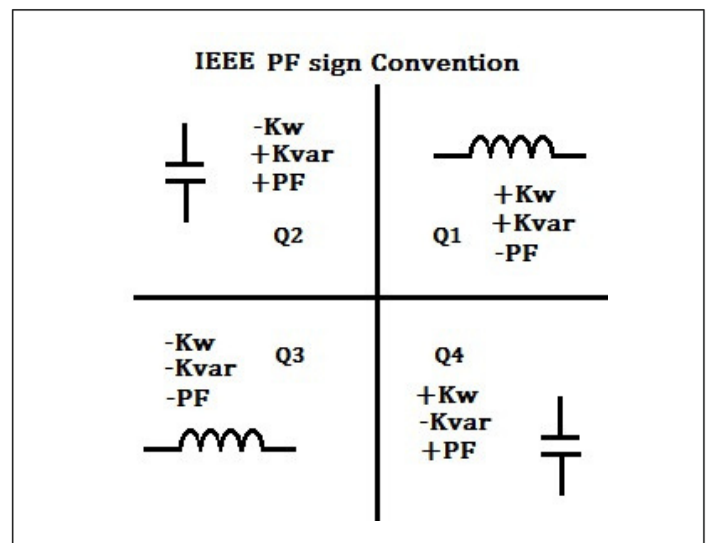

True PF and displacement PF:

- True power factor includes harmonic content. True PF is the ratio of the active power to the apparent power at the power outlet.
- Displacement power factor only considers the fundamental frequency. Displacement power factor can be defined as the cosine of the angle between the current and voltage.

Power factor Min/Max convention

The meter use specific convention for determining the power factor minimum and maximum values.

- For **negative** PF readings, the **minimum PF value** is the measurement closest to -0 for PF readings between -0 to -1, the **maximum PF value** is the measurement closest to -1 for PF readings between -0 to -1.
 - For **positive** PF readings, the **minimum PF value** is the measurement closest to +1 for PF readings between +1 to +0, the **maximum PF value** is the measurement closest to +0 for PF readings between +1 to +0.
- For communication, the power factor is displayed in the form of a PF register value as below.

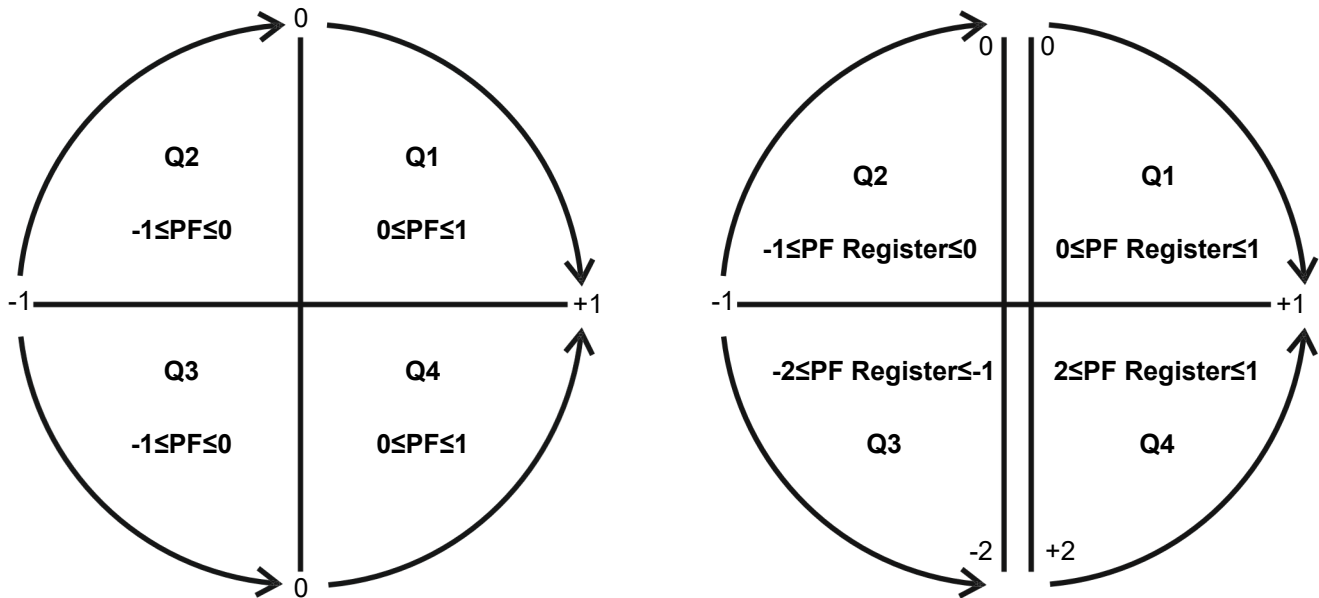

The power factor value is calculated from the PF register value using the following formula:

Quadrant	Power factor range	PF register range	PF formula
Quadrant 1	0 to +1	0 to +1	PF Value = PF register value
Quadrant 2	-1 to 0	-2 to -1	PF Value = (-2) - PF register value
Quadrant 3	0 to -1	-1 to 0	PF Value = PF register value
Quadrant 4	+1 to 0	+1 to +2	PF Value = (+2) - PF register value

Type of power factor	Range of power factor	Minimum power factor	Maximum power factor
Negative power factor reading	PF readings between -0 to -1.	Closest to -0	Closest to -1.
Positive power factor reading	PF readings between +1 to +0	Closest to +1.	Closest to +0

Demand measurement:

The meter can support demand measurements consisting of power and current demand readings as the cosine of the angle between the current and voltage.

The demand will be calculated using the demand calculation method configured in the meter.

There are four standard types of demand calculation methods, that meter supports: Fixed, Sliding, Fixed-Sliding, Thermal method.

The meter provides last, present, predicted, and peak demand values and a time stamp when the peak demand occurred.

- **Power demand (Total W, VAR, VA)**
- **Current demand (Average Amps)**

All demand values data can be accessed and reset via communication or from the meter front.

1. Sliding Demand:

Present and peak demand updates at the end of each sub-interval. Last demand lags one sub-interval. If demand duration selected is 3 and demand length selected is 2, then demand is updated at the end of 2 minutes. Here, interval is of 6 minutes and update time is 2 minutes.

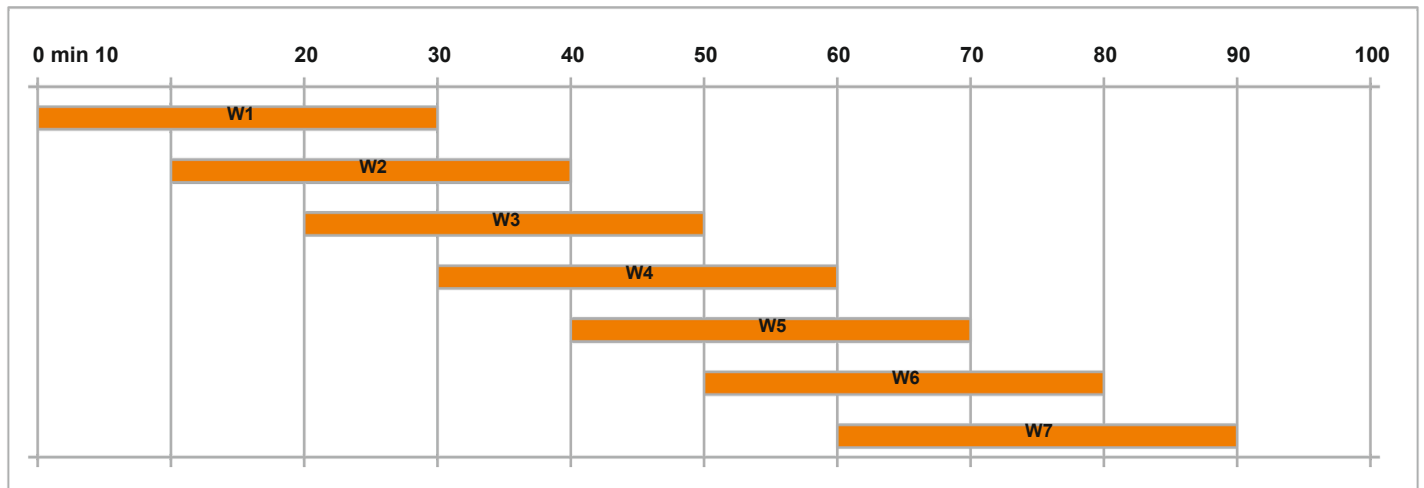

2. Fixed demand:

Present demand updates at the end of every 1 minute (fixed) and the peak and last demand values are updated at the end of interval.

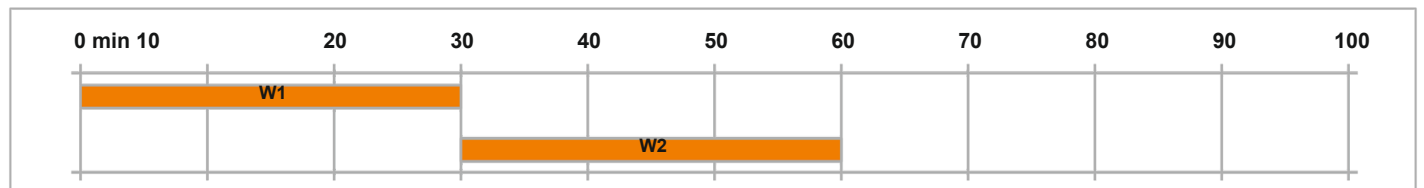

3. Fixed-sliding demand:

Present and peak demand updates every 15 seconds (if demand duration is between 1 and 15 minutes) or 60 seconds (if demand duration is between 16 and 60 minutes) and last demand is updated at the end of interval.

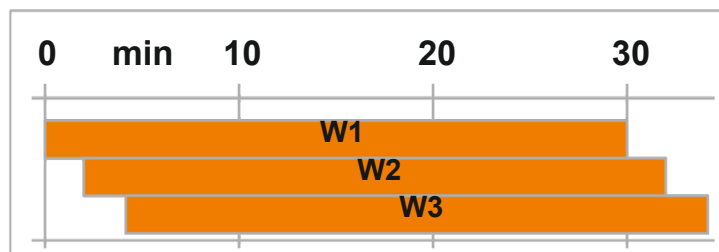

4. Thermal demand:

Athermal response is the one which is used to calculate thermal demand. By setting the DMD duration (1 to 60min) the thermal response curve can be derived.

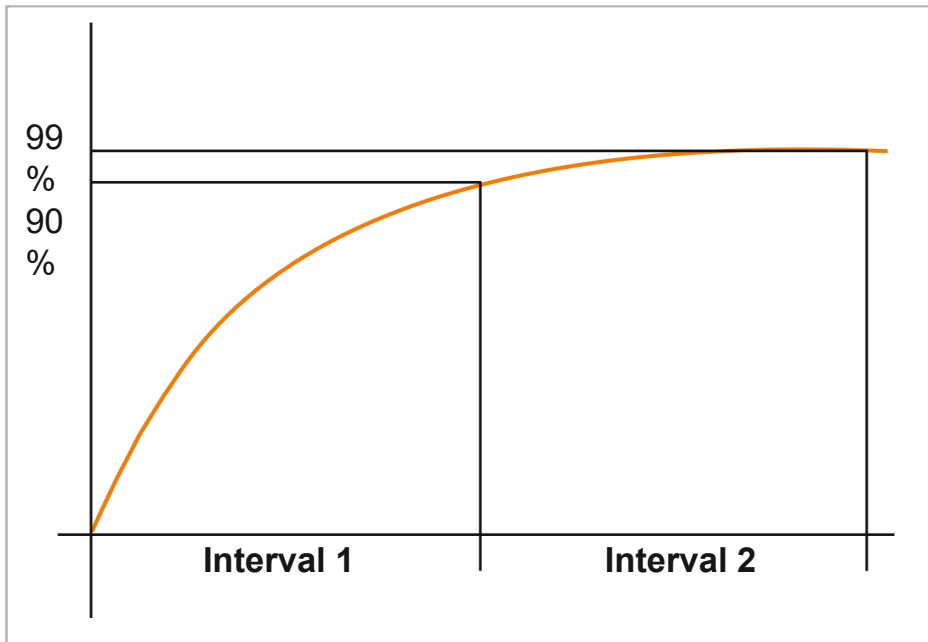

Energy - Mains / DG (Import / Export):

Accumulated energy (mains and DG both)

- Active, Apparent, Reactive energy
- Import - Per phase and Total
- Export - Per phase and Total
- Total NET (Import + Export)
- Total NET (Import – Export)

Last cleared energy (mains and DG both)

- Active, Apparent, Reactive energy
- Import - Per phase and Total
- Export - Per phase and Total
- Total NET (Import + Export)
- Total NET (Import – Export)

Energy Roll-over:

When any energy value exceeds the maximum value 999999.999 GWh, GVArh, GVAh, then that particular energy rolls over and stores the count at modscan address and starts accumulating fresh from 0. To response in increase in energy, the energy rollover automatically on display from WATT to KWATT then to MWATT and GWATT. Energy unit symbol will change to k/M/G depending on the value.

Case	Displayed Energy	Displayed Energy Unit	Updated Displayed Energy	Updated Displayed Energy Unit
1	999.999	kWh	0	MWh
2	999.999	GWh	0	Wh

Note : In Case 2 after energy roll-over, count gets updated at particular address. Displayed Energy & unit get updated as shown

Energy pulsing detailed method:

Within specific limits, the meter's energy pulsing LED and pulse outputs are capable of performing energy pulsing.

Energy pulsing at	Maximum pulse frequency	Max. No of Pulses / Sec
LED OUTPUT	40 Hz	36
PULSE OUTPUT	20 Hz	18

Configurable pulse width: 1 to 9999000 (per k_h)

Note: Pulse duration is fixed for LED output is 25ms and for POP output is 50ms

Calculation to allow the energy pulsing at LED output

LED Output will increment only if the total number of pulses is more than configured pulse width otherwise the LED pulsing count will be 0.

$$\begin{aligned}
 \text{Total No of pulses / Hr are calculated as} &= \frac{\text{Max. No of Pulses / Sec}}{\text{Total power}} \\
 &= \frac{36 \times 3600}{3.6 \text{ (kW}_{\text{Total}})} \\
 &= 36000/\text{Hr}
 \end{aligned}$$

Configured pulse width	Condition	LED output
10	Total No of pulses > Pulse width	LED pulsing will start incrementing as per observed energy
10000	Total No of pulses > Pulse width	LED pulsing will start incrementing as per observed energy
37000	Total No of pulses < Pulse width	LED pulsing will not start incrementing. Remains OFF.

The LED pulse count is dependent on the configured pulse width in relation to the incrementing energy as below table.

Sr No.	Configured LED pulse Width	Energy in kWh	LED pulse count
1	1	1.000	1
2	10	0.100	1
3	100	0.010	1
4	1000	0.001	1
5	10000	0.001	10
6	100000	0.001	100
7	1000000	0.001	1000
8	9999000	0.001	10000

Calculation to allow the energy pulsing at POP output

Pulse output will increment only if the total number of pulses is more than configured pulse width otherwise the POP count will be 0.

$$\begin{aligned}
 \text{Total No of pulses / Hr are calculated as} &= \frac{\text{Max. No of Pulses / Sec} \times 3600}{\text{Total power}} \\
 &= \frac{18 \times 3600}{3.6 \text{ (kW}_{\text{Total}})} \\
 &= 18000/\text{Hr}
 \end{aligned}$$

Configured pulse width	Condition	LED output
10	Total No of pulses > Pulse width	POP will start incrementing as per observed energy
10000	Total No of pulses > Pulse width	POP will start incrementing as per observed energy
19000	Total No of pulses < Pulse width	POP will not start incrementing.

The POP count is dependent on the configured pulsewidth in relation to the incrementing energy as below table.

Sr No.	Configured POP pulse width	Energy in kWh	POP count
1	1	1.000	1
2	10	0.100	1
3	100	0.010	1
4	1000	0.001	1
5	10000	0.001	10
6	100000	0.001	100
7	1000000	0.001	1000
8	9999000	0.001	10000

Terminology

RPM:

Meter provides the measurement of rotational speed of motor. usually displays value in terms of RPM. The speed a synchronous motor will run can be determined by the electrical service using. No of poles are set table through communication or from the meter front.

ON hour:

ON hour shows how long the meter has been powered up. ON hour data can be accessed via communication or from the meter front under self-test mode.

Import run hour-Mains:

Import run hours-Mains show how much time a load has been running, based on accumulated energy – Import (delivered) of mains supply. run hour import mains data can be accessed via communication or from the meter front under self- test mode. It can be reset via communication or meter front.

Export run hour-Mains:

Export Run hours-Mains show how much time a load has been running, based on accumulated energy – Export (received) of mains supply. run hour export mains data can be accessed via communication or from the meter front under self-test mode. It can be reset via communication or meter front.

Import run hour- DG:

Import runhours-DG show how much time a load has been running, based on accumulated energy – Import(delivered) of DG supply. run hour import DG data can be accessed via communication or from the meter front under self-test mode. It can be reset via communication or meter front.

Export run hour- DG:

Export runhours-DG show how much time a load has been running, based on accumulated energy – Export (received) of DG supply. run hour export DG data can be accessed via communication or from the meter front under self-test mode. It can be reset via communication or meter front.

Load Run Hour:

Load Run hour shows how long a load has been running, based upon the load timer set point set in communication. (minimum current). active load timer data can be accessed via communication or from the meter front under self-test mode. It can be reset via communication or meter front.

Auxiliary interrupts:

Auxiliary interrupts shows number of auxiliary supply interruptions. Auxiliary interrupts data can be accessed via communication or from the meter front under self-test mode. It can be reset via communication or meter front.

Voltage sequence detection:

Meter performs the analysis of the input voltage signals. It detects the wrong phase sequence or failure of one of the input voltage and displays the result upon pressing  key for 3 seconds.

1. OK phase sequence - "**Clockwise**"
2. Wrong phase sequence - "**Anticlockwise**"
3. Failure of one of the input voltage - "**Invalid**"

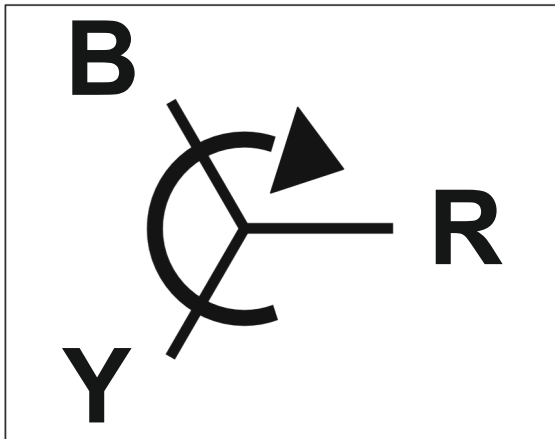

CLOCKWISE

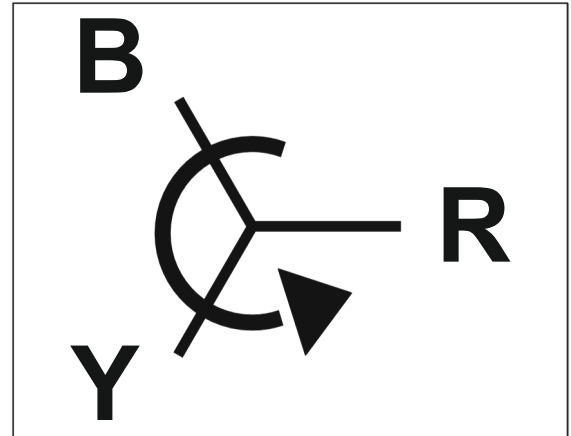

ANTI-CLOCKWISE

Current polarity (CT reversal detection and Correction)

The meter supports a setting that allows the user to change the current polarity in the meter via communication and from the panel in configuration mode. This is beneficial if the CT's have been installed in the reverse direction polarity.

Configure the CT through the front panel according to the CT polarity shown on the current reversal detection page. Changing the current polarity to negative is basically changing the phase angle of the current by 180 degrees, making it possible to correct any installation errors. There is no need to change the physical wiring.

By default the current direction is configured to positive for CT1, CT2 and CT3 i.e., NONE.

Upon pressing the key  for 3 seconds, the current reversal detection page will appear with the CT number of the input current that is reversed in polarity.

1. 1st phase CT polarity has reverse connection - "**1**"
2. 1st and 2nd phase CT polarity has reverse connection - "**12**"
3. 1st, 2nd, 3rd phase CT polarity has reverse connection - "**123**"

Note: CT polarity correction should be referred when input active power is positive.

CT correction changes can be done through meter configuration.

Real-time clock:

The meter supports with real-time clock. The RTC parameters are date and time shown in the form of DD:MM:YY and HH:MM:SS respectively. The RTC parameters data can be accessed via communication or from the meter front.

Battery specifications: Cr2032

Diameter: 20mm

Height: 3.2mm

Nominal capacity: 220mAh

Battery voltage: 3V

Operating voltage: -30 °C to 70 °C

COMMUNICATION

The meter is equipped with both Serial and Ethernet communication with MODBUS TCP and MODBUS RTU protocols.

Serial Communication(RS 485):

The meter has RS485 port for the purpose of Serial communication, the RS485 bus can support up to 32 devices connected to it.

In RS485 bus the devices are connected in point-to-point configuration. With (+) and (-) terminals of devices connected in series.

Note: Use a shielded twisted pair RS485 cable

The total distance for devices connected on an RS-485 bus should not exceed 500 m (1640 ft)

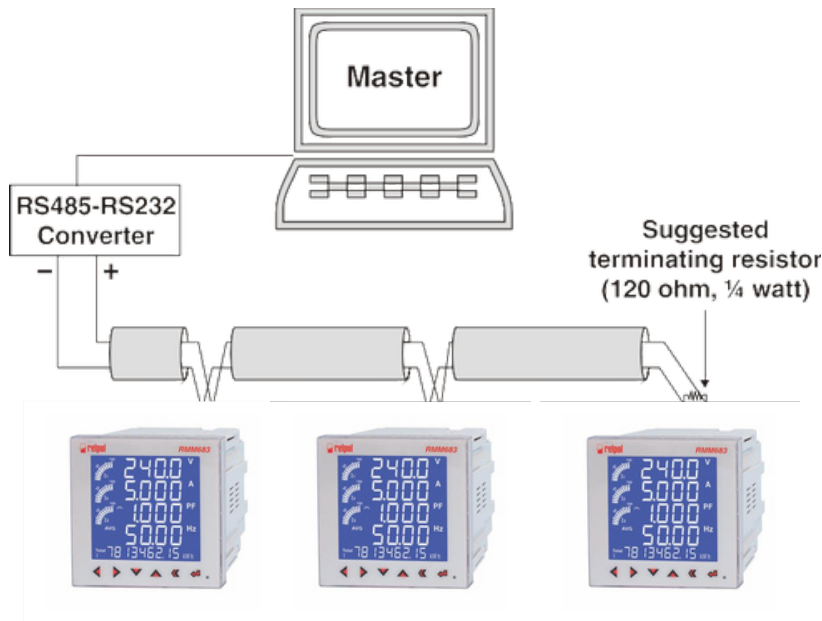

Contact sales for PC based monitoring software to communicate with the meters.

Wiring diagram

Configuration of RS485 network need to be performed after wiring the RS485 port in order to communicate with the network.

Each device on the same Rs485 communications bus must have a unique slave id and all connected devices must be set to the same protocol, baud rate, and parity (data format).

Serial interface:

Serial standard	RS485
No. of ports	1
Protocol	Modbus RTU
Baudrate	9600, 19200, 38400, 57600, 115200 bps
Data bits	8
Stop bits	1, 2
Parity	None, Odd, Even
RS485 data direction control	Auto

Note - Serial communication configuration process on page xx

- **Ethernet:**

Overview:

A serial to ethernet converter is a small electronic device which can convert ethernet IP/TCP packets to either RS232, RS485 serial data signals and vice versa. Most commonly it is used for connecting a serial RS232, RS485 device such as a serial printer, Energy meter, Bar code scanner, Scale, GPS, Sensor or any other consumer or industrial device with a serial interface, to a computer over a standard LAN network. The advantage of this is obvious; you will be able to control, monitor and communicate with your serial device remotely from a central computer. No need to walk all the way down to the other end of the factory to check your serial device. A picture showing basic architectural overview is as shown below.

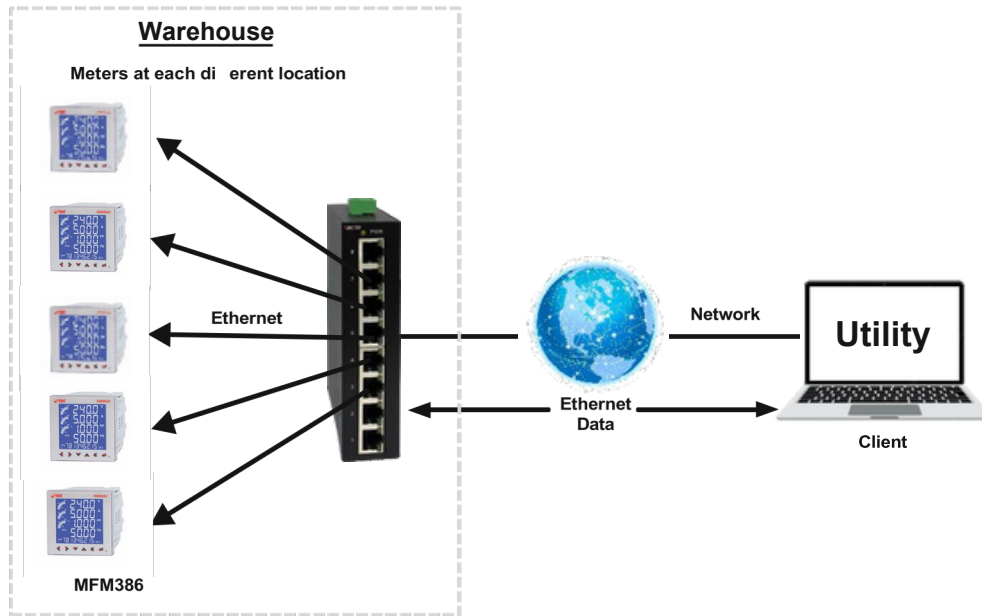

The meter has a ethernet communication port which uses MODBUS TCP protocol and MODBUS TCP over RTU to communicate at data speed up to 100Mbps. Cat 5 cable to be used for the connection of meter's ethernet port. The ethernet connection between client and server should be positioned in a location that minimizes the overall length of ethernet cable routing, a router can be used if the transmission distance is less than 100m.

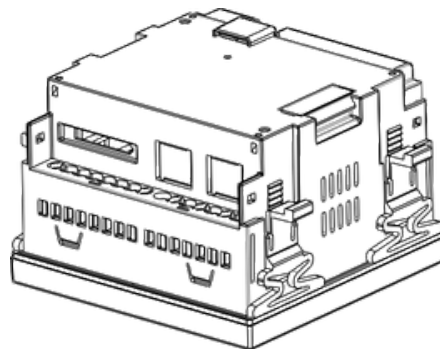

The ethernet port setup allows you to assign a unique IP address to the meter so you can to access the meter's data or configure the meter remotely through the ethernet port. All devices must have a unique IP address and be set to the same subnet mask and gateway, to communicate with meter through ethernet.

Ethernet interface:

Connector	8 pin RJ45
No. of ports	1
Speed	10/100 Mbps
Transmission distance	Max upto 100 m
Protocol	MODBUS TCP over RTU, Modbus TCP
Standards	IEEE802.3, IEEE802.3u
Magnetic isolation protection	1.5KV
IP configuration	DHCP, Static IP
Signal	Tx+, Tx-, Rx+, Rx-

Ethernet port:

PIN	Signal
1	TXP
2	TXM
3	RXP
4	-
5	-
6	RXM
7	-
8	-

LED indication & Reset key

Indicator	Function	Description
ACT	Power on	Converter has power
Link	Network link	ON when network is connected
Reset switch	Factory reset	Reset switch for factory reset of ethernet

Device default settings:

Networksetting:Dynamic IP, TCP protocol

Serial setting: 115200,8,N,1

Mode setting: Transparent mode, TCP server, MODBUS TCP

Device factory reset settings:

In order to factory reset the meter ethernet to default setting press and hold the reset button on the back of the meter for more than 5 seconds

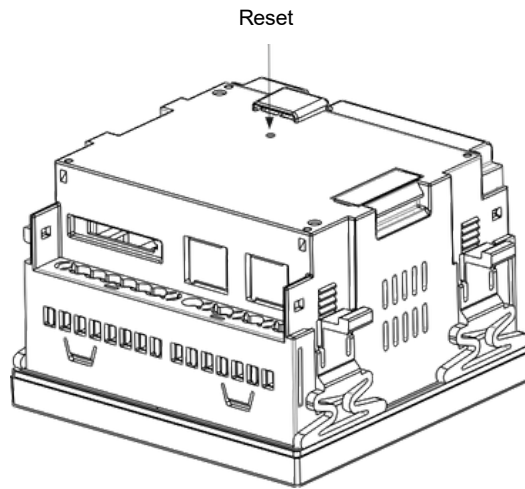

Before communicating with ethernet, make sure you obtain your meter's IP address information from your network administrator or IT department.

Configuration requirements can include:

Windows utility: Used for Ip finding, network configuration, serial configuration configuration OS support for utility: 32 bit/64-bit Windows XP/Vista/7/8/8.1/10, windows server 2003/2008/2008 R2/2012 R2

Configuring the device:

The device configuration is managed by a windows utility called RELPOL finder. The details regarding how to use the utility are as given below.

Relpol finder utility overview:

The RELPOL finder utility is used to find out and configure Relpol ethernet devices on the network. The utility will list all the RELPOL devices on the ethernet network and the information will contain IP address, MAC Address and Device description string. This utility can be further used to configure various Network settings, Serial settings and Mode settings of the S2E device.

- **Step 1:** Run the RELPOL finder utility and it should look something like this when the screen pops up

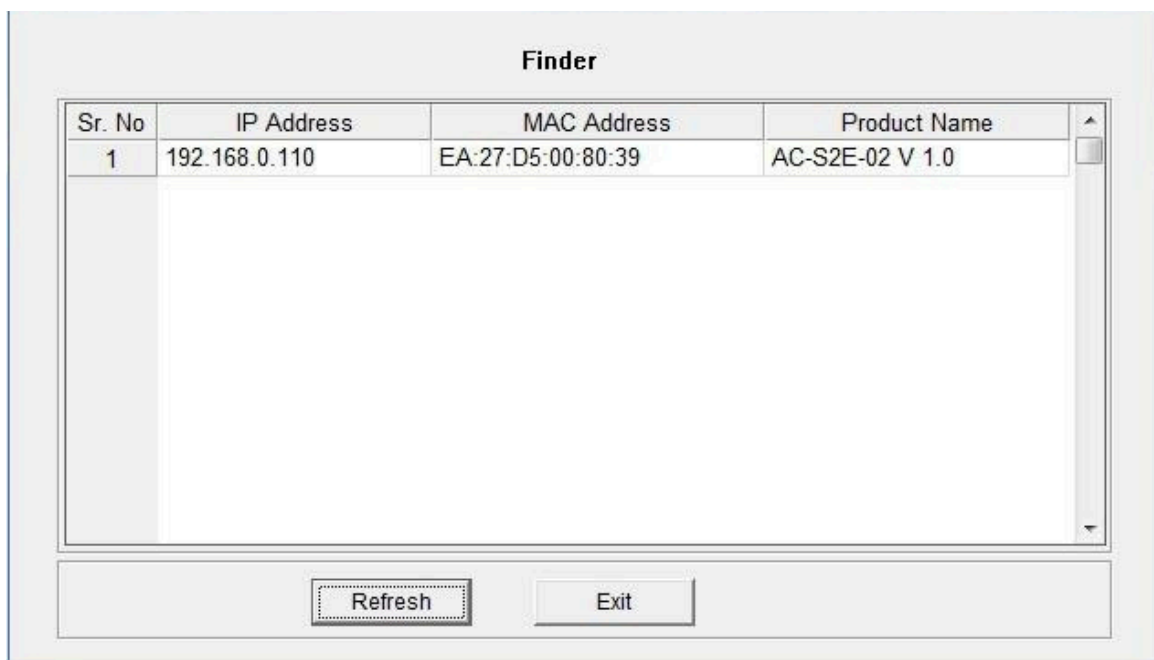

As shown above the screen display the RELPOL devices in the network using IP ADDRESS, MAC ADDRESS and PRODUCT NAME. The device to be configured should be seen in this list. If not then you can refreshing the screen by pressing the refresh button.

- **Step 2** : Double click on the IP ADDRESS of the device you want to configure. The screen pops up showing existing configuration settings in various settings tabs which are Network, Serial and Mode. The screen displayed is as shown below. You can go to any tab just to view the existing settings. Just click on the tab and existing settings will be displayed. All 3 images showing existing settings are shown below. This is just an example and actual value in different settings tab will vary as per existing config in the device.

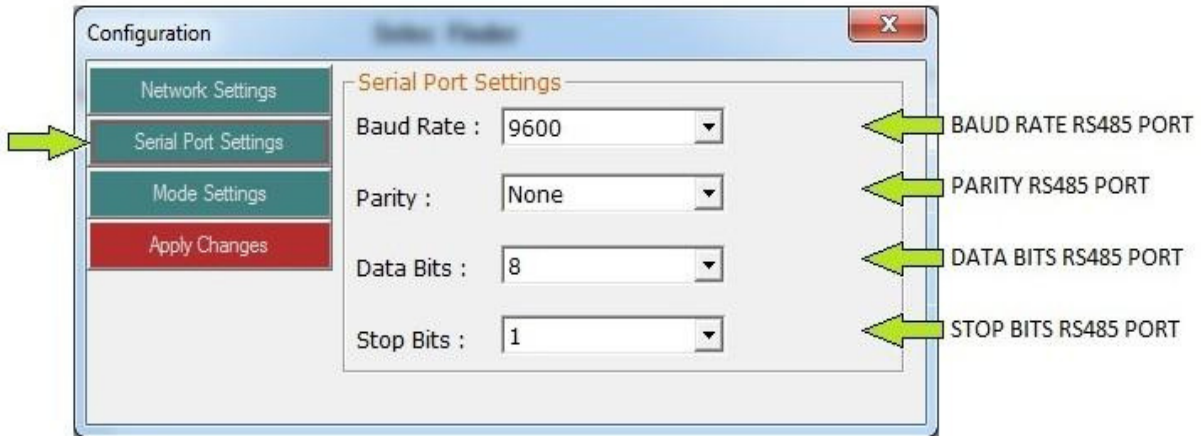
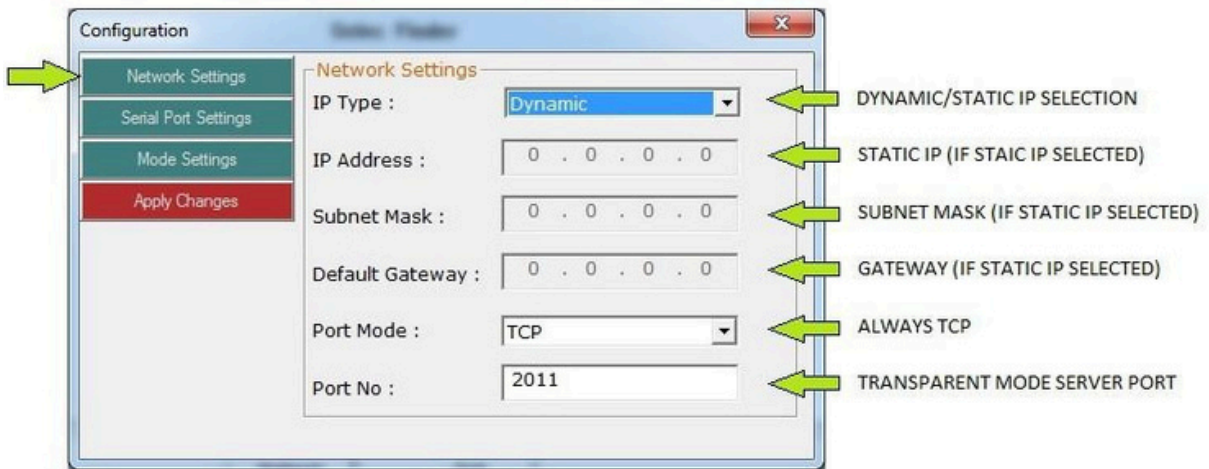

Note : If you are using the RMM-683 device, select a baud rate of 115200.

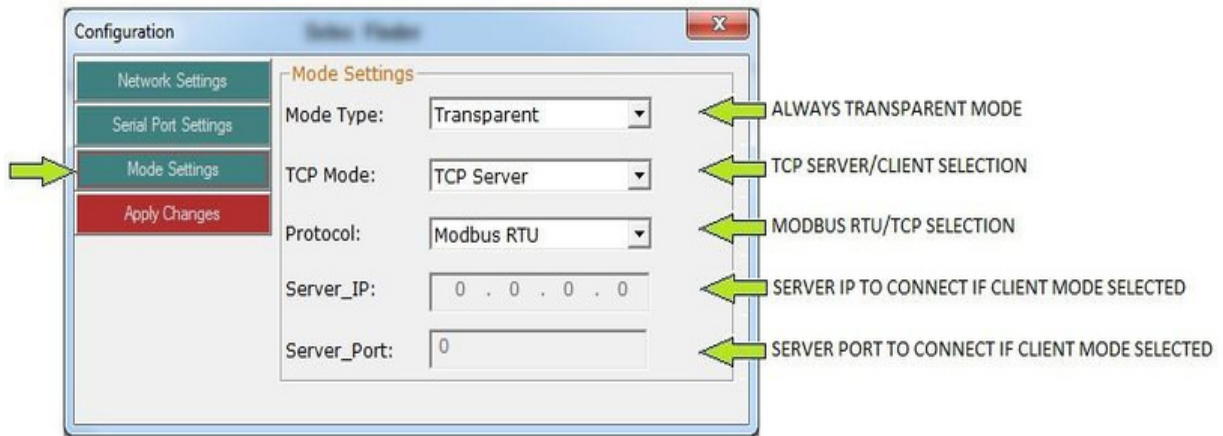

Note :-

- If you are using the Modscan utility, select **MODBUS TCP** as the protocol in the "Select Finder" option.
- If you are using the RMMS utility with Modbus RTU over TCP/IP, choose **MODBUS RTU** as the protocol in the "Select Finder" option
- If you are using **MODBUS TCP** in the RMMS utility, Select MODBUS TCP as the protocol in the "RELPOL Finder" option
- **Step 3:** Make any relevant changes in the config. and then click on **Apply changes** button which should display the following screen on successful communication. Click ok and close the window.

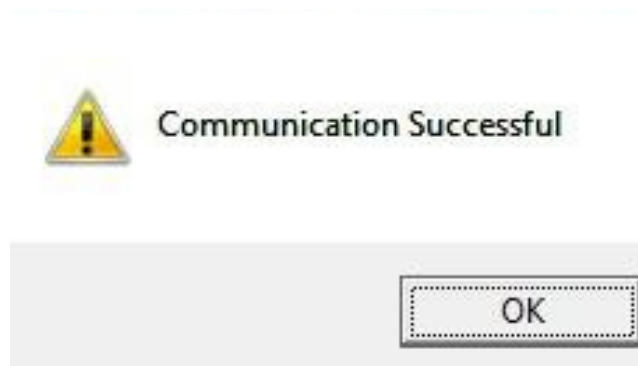

In case of error click ok on error message window and Restart the procedure from Step 1.

MULTI-TARIFF

Multi - Tariff:

The meter supports multiple tariffs for the measurement and monitoring of energy used for the purpose of costing and billing.

Meter allows you to use 4 different tariff containers to store the accumulated energy data. 4 tariff with each having 4 time slots settings. You can configure different tariff condition using tariff setup.

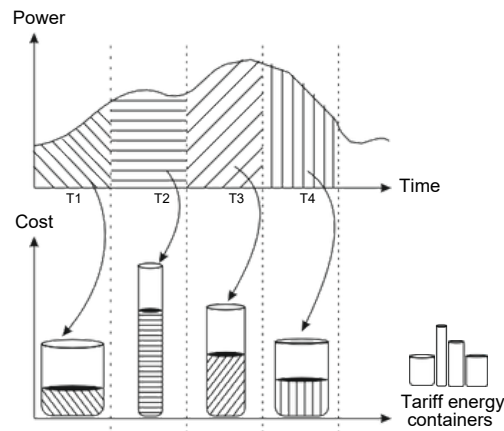

In the provided example, the energy consumed corresponds to the area beneath the power curve. Usually, utility companies establish tariff schedules such that energy costs are elevated during periods of high demand or consumption. The configuration of these "tariff energy containers" dictates the rate at which they fill, directly impacting rising energy expenses. Tariff T1 offers the lowest price per kWh, while tariff T2 imposes the highest cost.

There are different tariff modes you can use to determine what tariff is applied and when: Command mode, Time of day mode, and Input mode.

Based on the conditions different tariff modes can be used:

Command mode overview:

In this mode you can send a MODBUS command to the device for the activation of certain tariff. This tariff measure energy until different tariff MODBUS command is sent

Time of use mode overview:

In this mode to store energy or input metered data, based on the time of year (Day, Month), the type of day (every day, weekend, weekday or a specific day of the week), or time of use a tariff schedule can be created

Date & Time format table:

Parameter	Values	Description
Year	24-90	The calendar year
Month	1 to 12	The calendar month, where 1 = January, 2 = February, 3 = March, 4 = April, 5 = May, 6 = June, 7 = July, 8 = August, 9 = September, 10 = October, 11 = November, 12 = December.
Day	1 to 31	The calendar day of the month.
Weekday	Monday to Sunday	The calendar day of a week.
Hour	0 - 23	Real time clock hour in 24 hr format
Minute	0 - 59	Real time clock minutes
Seconds	0 - 59	Real time clock seconds

Valid tariffs:

A valid must follow tariffs conditions:

- Tariffs cannot overlap, each tariff must have unique time period
- Time of use tariffs do not adjust for daylight savings time
- February 29th in a leap year can be a time of use tariff, but it is not recommended to have February 29th as a start or end date, as that tariff would be invalid for non-leap years
- Except for leap years, tariff dates are not year-specific; if you wanted to create a tariff that starts on the first Monday in June, you need to enter the date for that year, then manually update the tariff information for the subsequent years

Methods for creating a tariff:

The device validates as you enter tariff information, it allows you to change the entered information or disables the tariff in the information is invalid:

- Start time can only be earlier than end time for tariffs that are applied every day. You can create a daily tariff that starts at 06:00 and ends at 11:00, but these times are only valid for the everyday tariff and invalid for the other tariff types
- Start day must be earlier than end day if the days are in the same month. You cannot create a tariff that starts June 15 and ends June 12
- The tariff setting starts from selecting the DAY TYPE from every day, weekend, weekday or a specific day of the week and can specify the time of use. For example, a four tariff configuration could have every day in the year divided into six-hour tariff periods or could have two tariffs for weekends and two tariffs for weekdays

Tariff configurations examples:

		Tari			
		1	2	3	4
Timeslot 1	Type	Everyday	Weekdays	Weekdays	Weekdays
	Start date	01/01/23	01/05/23	01/01/23	01/09/23
	End date	23:30:00	05:00:00	07:00:00	19:30:00
	Start time	31/12/23	30/09/23	30/04/23	31/12/23
	End time	00:29:59	10:00:00	10:00:00	20:15:00
Timeslot 2	Type	Everyday	Weekdays	Weekdays	Weekdays
	Start date	01/01/23	01/05/23	01/01/23	01/09/23
	End date	01:00:00	11:00:00	13:00:00	20:30:00
	Start time	31/12/23	30/09/23	30/04/23	31/12/23
	End time	02:29:59	13:00:00	14:00:00	21:15:00
Timeslot 3	Type	Everyday	Weekdays	Weekdays	Weekdays
	Start date	01/01/23	01/05/23	01/01/23	01/09/23
	End date	03:00:00	15:30:00	15:30:00	21:30:00
	Start time	31/12/23	30/09/23	30/04/23	31/12/22
	End time	03:49:59	17:00:00	16:00:00	22:15:00
Timeslot 4	Type	Everyday	Weekdays	Weekdays	Weekdays
	Start date	01/01/23	01/05/23	01/01/23	01/09/23
	End date	04:15:00	20:00:00	16:15:00	22:30:00
	Start time	31/12/23	30/09/23	30/04/23	31/12/23
	End time	04:59:59	23:29:59	17:30:00	21:15:00

As seen in the above table the **Tariff 1** stores the energy of whole year 2022 of each day from 12:00:00 AM to 11:59:59 PM
Tariff 2 stores energy of Midnight to 9:00 AM also from 5:00 to Midnight for months February to June of weekdays only
Tariff 4 will store completer energy of month April, May, June, October, November, December as the day types and timeslot aligns for these months. Rest Every day, weekdays, weekend energies will be stored in tariff 4 according to time limit applied

Configuring time of day mode tariffs:

A valid must follow tariffs conditions:

- Tariffs cannot overlap; each tariff must have a unique time period
- Time of use tariffs do not adjust for daylight savings time
- February 29th in a leap year can be a time of use tariff, but it is not recommended to have February 29th as a start or end date, as that tariff would be invalid for non-leap years
- Except for leap years, tariff dates are not year-specific; if you wanted to create a tariff that starts on the first Monday in June, you need to enter the date for that year, then manually update the tariff information for the subsequent years

• Input mode overview:

In Input type tariff there are 3 different modes which takes No. Of Digital input as 2, 3 or 4

The input mode the energy is stored in the specified tariff based on the respective configured DI in the meter
 If a digital input is used for tariff, it cannot be used for an exclusive association (such as Demand sync or Input metering), but digital inputs can be shared with a non-exclusive association (such as alarms)

The DI are used as binary counters to identify tariff, where ON = 1 and OFF = 0, and digital input 2 as most significant bit(MSB) and digital input 1 as least significant bit(LSB)

Tariff configurations with different input modes:

Using 2 digital inputs

DI1 Status	DI2 Status	Stored in
0	1	Tariff 1
1	0	Tariff 2

Using 3 digital inputs

DI1 Status	DI2 Status	Stored in
0	1	Tariff 1
1	0	Tariff 2
1	1	Tariff 3

Using 4 digital inputs

DI1 Status	DI2 Status	Stored in
0	0	Tariff 1
0	1	Tariff 2
1	0	Tariff 3
1	1	Tariff 4

• **Fixed Tariff :**

The fixed tariff feature in meter enables users to accurately measure and monitor energy consumption for billing purposes. It initiates this process by recording energy usage starting from the user specified date onwards

• Configure fixed Tariff-Billing parameters

Parameter	Holding register	Range	Description
Hour	40348	0-23	Set the hour for tariff calculation
Minutes	40349	0-59	Set the minutes for tariff calculation
Seconds	40350	0-59	Set the seconds for tariff calculation
Day	40351	1-31	Set the day of the month for tariff calculation
Month	40352	1-12	Set the month for tariff calculation

Note :- All five parameters must be set simultaneously. If any parameter is left unconfigured, all parameters will default to zero

• **Retrieve energy data**

After configuration, stored energy data can be read from the input registers as follows:

Time period	Stored energy registers	Beginning of period registers	Description
Current day	30726-30746	30750-30770	Access daily energy consumption and generation data for the current year
Previous day	30774-30794	30798-30818	Access yesterday's energy consumption and generation data for the current year
Current month	30822-30842	30846-30866	Access daily energy consumption and generation data for the current year
Previous months (1-12)	30870-31418	30894-31442	Access yesterday's energy consumption and generation data for the current year
Current year	31446-31466	31470-31490	Access daily energy consumption and generation data for the current year
Previous year	31494-31514	31518-31538	Access yesterday's energy consumption and generation data for the current year

- **Energy categories**

The energy data covers the following parameters:

Category	Description
Total import KWH	Total import active energy
Total export KWH	Total export active energy
Total import KVAH	Total import apparent energy
Total export KVAH	Total export apparent energy
Total import KVARH	Total import reactive energy
Total export KVARH	Total export reactive energy

ALARMS

Alarms overview: Meters are equipped with a robust alarm system designed to alert users when abnormal conditions are detected. These

conditions could include errors, unexpected events, or measurements that deviate from standard operating ranges. The alarms are flexible and can be configured based on specific set points to monitor critical parameters, events, or potential issues in your electrical system. Depending on the nature of the detected event, the meter supports high, medium, and low-priority alarms, ensuring that users can address concerns promptly and appropriately.

- **Key features include:**

Customizable alerts: Users can modify alarm settings, such as priorities, to align with specific operational needs.

- **Alarm creation:**

The meter's advanced features allow users to define custom alarms tailored to unique system requirements.

- **Event logging:**

All alarm events are logged in the meter for easy tracking and analysis. Meters offer a powerful and user-friendly alarm management system, enabling users to maintain optimal system performance and reliability.

- **Available Alarms:**

Meters supports a number of different alarm types.

Type	Number
Unary	4
Digital	1
Standard	28

- **Unary alarms:**

Unary alarms are specific alerts designed to monitor and signal individual events or conditions. They insure efficient detection of issues like power-up, reset, diagnostics, and phase reversal.

Available unary alarms:

The power meter has four unary alarms

Alarm label	Description
Meter powerup	Meter powers on after losing control power.
Meter reset	Meter resets for any reason.
Meter diagnostic	Alert about issues or irregularities identified during self-diagnostic checks.
Phase reversal	Detects incorrect phase sequencing in three-phase power system.

Digital alarms

The meter has one digital alarms for alarming on status input status. The digital alarms are active when the associated enable input is ON. The pickup and dropout time delays are configured in seconds.

• **Digital Alarms:**

To prevent false triggers from erratic signals, you can set up pickup and dropout time delays for the digital alarm.

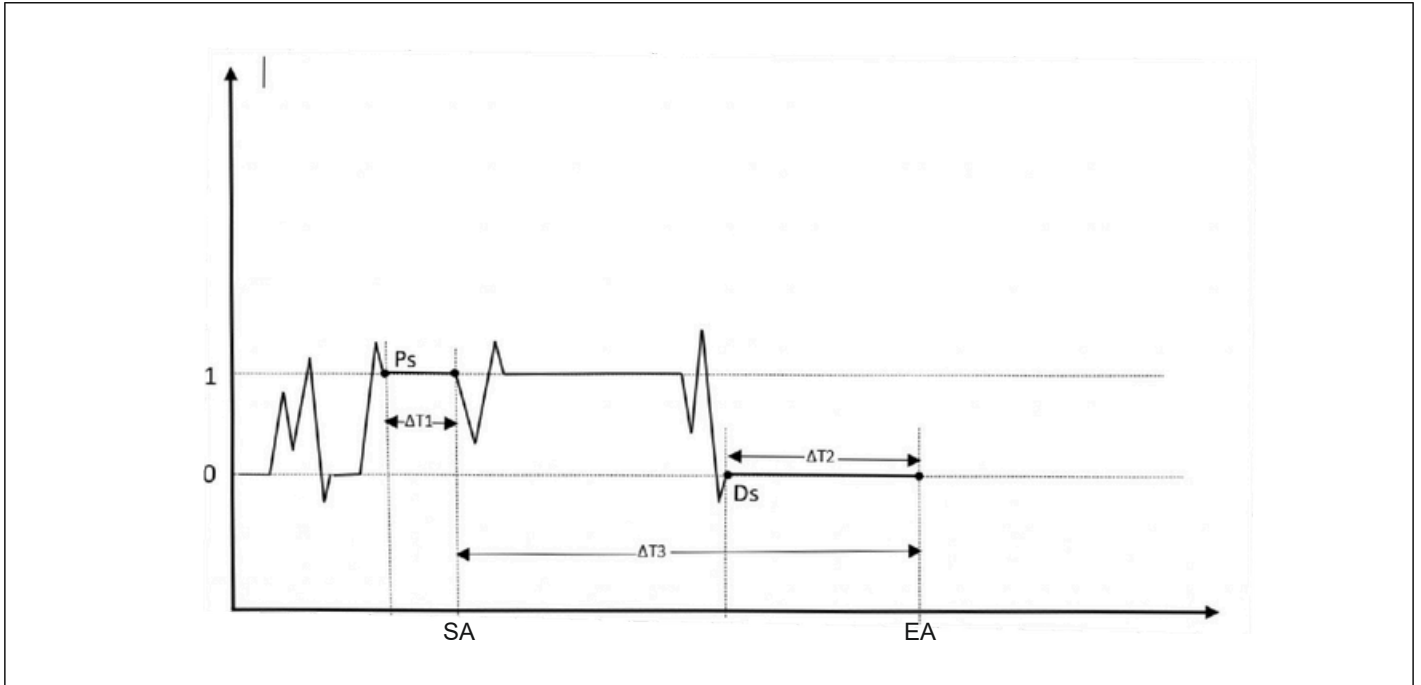

PS	Pickup setpoint (1 = ON)
DS	Dropout setpoint (0 = OFF)
$\Delta T1$	Pickup time delay (in seconds)
SA	Start of alarm condition
$\Delta T2$	Dropout time delay (in seconds)
EA	End of alarm condition
$\Delta T3$	Alarm duration (in seconds)

NOTE: To prevent filling the alarm log with nuisance alarm trips, the digital alarm is automatically disabled if the digital input changes state more than 4 times in one second or more than 10 times in ten seconds. In this case, you must re-enable the alarm using the display or utility

Standard alarms:

TheMeter has 28 Standard over / under alarms. Majority of standard alarms are three-phase, but reported as single phase alarms. Alarms can be used for controlling Relay and Digital output. Standard Alarms are configured by following values:

- Enable-disable (default) or enable
- Pickup setpoint (magnitude)
- Pickup time delay (in seconds)
- Dropout setpoint (magnitude)
- Dropout time delay (in seconds)
- Priority (High / Medium / Low / None)
- DO
- RO - Alarm on the relay output

Note:

- RO Can be configured only through Utility if External RO is connected and in Control Mode of RO ALARM is selected
Current, Voltage, Power, Demand and Frequency related alarms are configurable through meter front rest are configured using utility

- **Example of over and under setpoint (standard) alarm operation**

The meter supports over and under setpoint conditions on standard alarms. A setpoint condition occurs when the magnitude of the signal being monitored crosses the limit specified by the pickup setpoint setting and stays within that limit for a minimum time period specified by the pickup time delay setting.

The setpoint condition ends when the magnitude of the signal being monitored crosses the limit specified by dropout setpoint setting and stays within that limit for a minimum time period specified by dropout time delay setting

Over setpoint When the value rises above the pickup setpoint setting and remains there long enough to satisfy the pickup time delay period ($\Delta T1$), the alarm condition is set to ON. When the value falls below the dropout setpoint setting and remains there long enough to satisfy the dropout time delay period ($\Delta T2$), the alarm condition is set to OFF

The meter records the date and time when the alarm event starts (SA) and when it ends (EA). The meter also performs any task assigned to the event, such as operating a digital output. The meter also records maximum values (Max1, Max2) before, during or after the alarm period

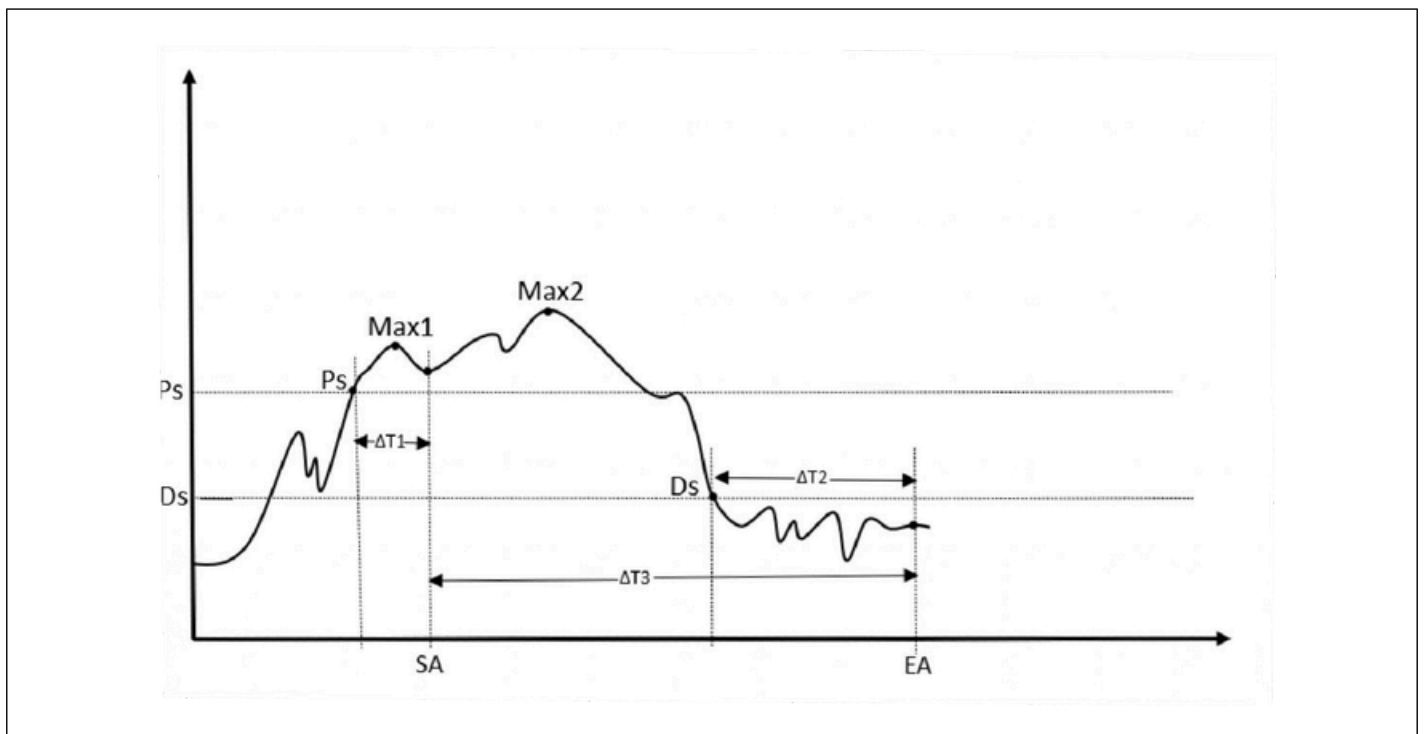

PS	Pickup setpoint (1 = ON)
DS	Dropout setpoint (0 = OFF)
$\Delta T1$	Pickup time delay (in seconds)
SA	Start of alarm condition
$\Delta T2$	Dropout time delay (in seconds)
EA	End of alarm condition
$\Delta T3$	Alarm duration (in seconds)
MAX1	Maximum value recorded during pickup period
MAX2	Maximum value recorded during alarm period

Under setpoint

When the value falls below the pickup setpoint setting and remains there long enough to satisfy the pickup time delay period ($\Delta T1$), the alarm condition is set to ON. When the value rises above the dropout setpoint setting and remains there long enough to satisfy the dropout time delay period ($\Delta T2$), the alarm condition is set to OFF.

The meter records the date and time when the alarm event starts (SA) and when it ends (EA). The meter also performs any task assigned to the event, such as operating a digital output. The meter also records minimum values (Min1, Min2) before, during or after the alarm period.

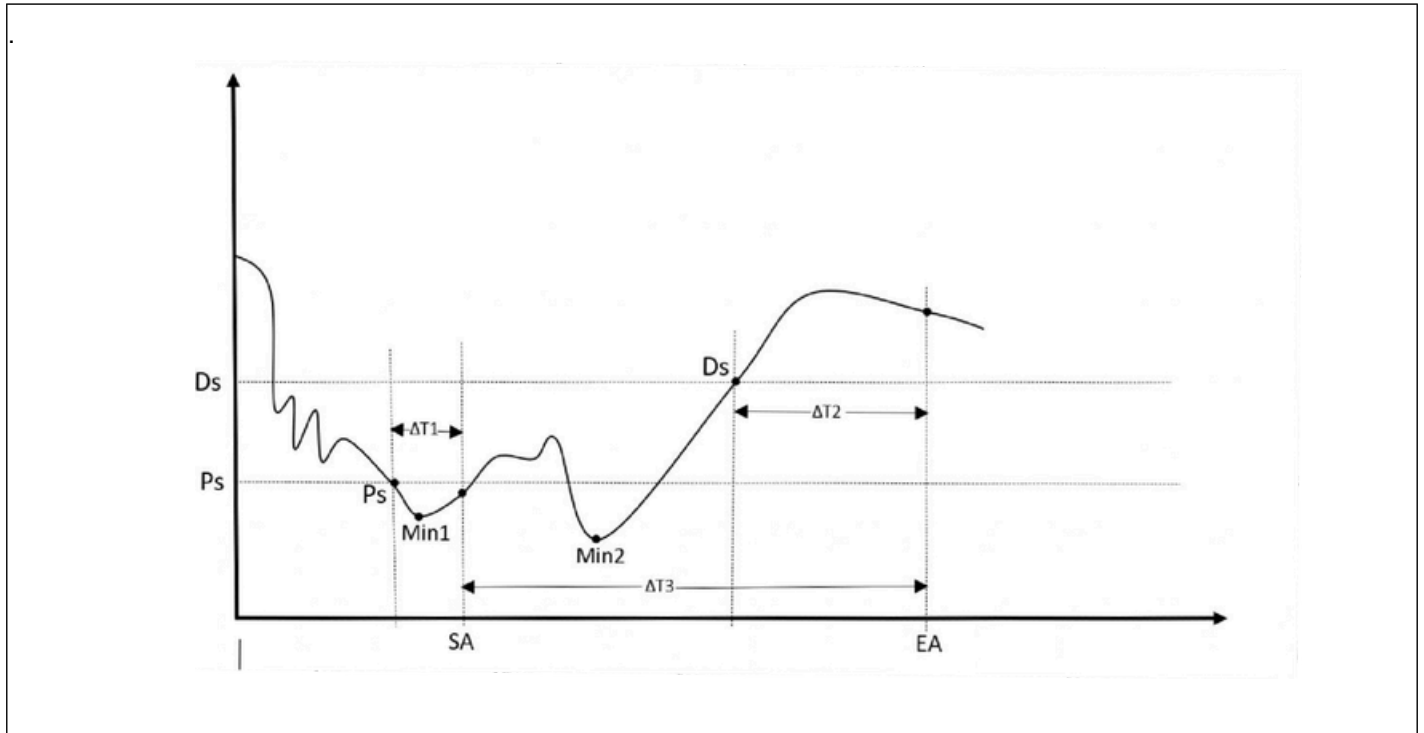

PS	Pickup setpoint (1 = ON)
DS	Dropout setpoint (0 = OFF)
$\Delta T1$	Pickup time delay (in seconds)
SA	Start of alarm condition
$\Delta T2$	Dropout time delay (in seconds)
EA	End of alarm condition
$\Delta T3$	Alarm duration (in seconds)
MIN1	Maximum value recorded during pickup period
MIN2	Maximum value recorded during alarm period

Available standard alarms:**Table of list of standard Over / Under alarms**

Alarm number	Alarm name
1	Over Current, Phase
2	Under Current, Phase
3	Over Current, Neutral
4	Over Voltage, L-L
5	Under Voltage, L-L
6	Over Voltage, L-N
7	Under Voltage L-N
8	Over Voltage Unbal
9	Over Voltage THD
10	Phase Loss
11	Over kW
12	Over kVAR
13	Over kVA
14	Over kW Dmd, Pres
15	Over kW Dmd, Last
16	Over kW Dmd, Pred
17	Over kVAR Dmd, Pres
18	Over kVAR Dmd, Last
19	Over kVAR Dmd, Pred
20	Over kVA Dmd, Pres
21	Over kVA Dmd, Last
22	Over kVA Dmd, Pred
23	Over Frequency
24	Under Frequency
25	Lead-Lag PF, True
26	Lead-Lag PF, Disp
27	Over RTD
28	Under RTD

Power factor alarm: An alarm can be configured for either Leading Power Factor or Lagging Power Factor, allowing for the monitoring of the circuit's power factor when it exceeds or falls short of the threshold you have established. The Leading PF and Lagging PF alarms use the power factor quadrants

Four quadrant power factor information: Floating point registers

The meter also provides PF information (including sign and quadrant) in single floating point registers for each of the PF values (for example, per-phase and total values for true and displacement PF, and associated minimums and maximums). The meter performs a simple algorithm to the PF value then stores it in the appropriate PF register.

The meter and software interpret these PF registers for reporting or data entry fields according to the following diagram:

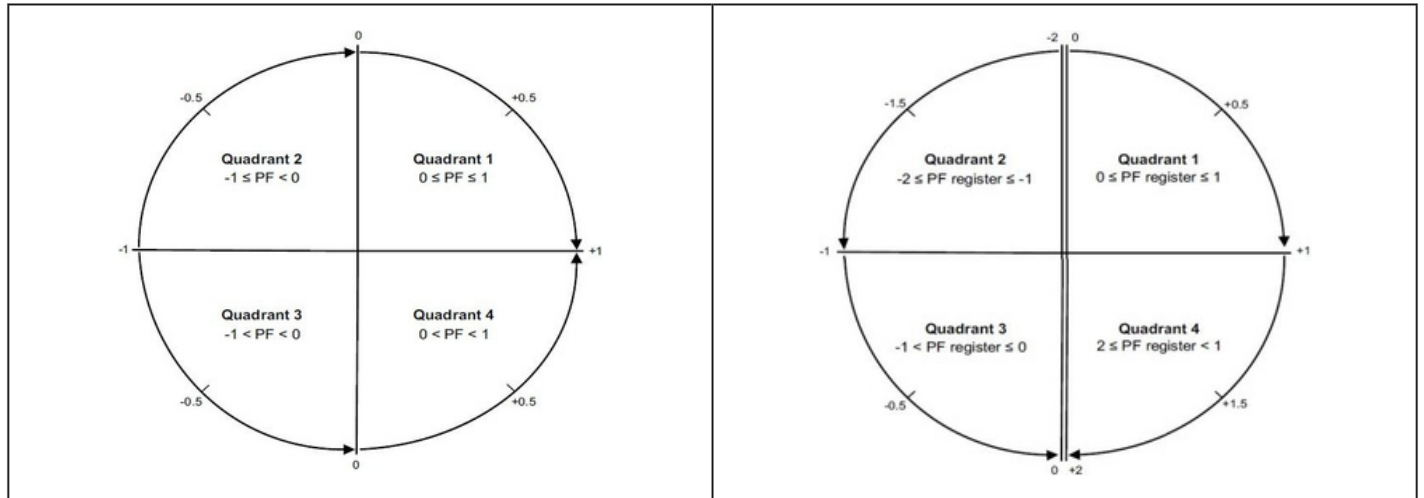

The PF value is calculated from the PF register value using the following formulas:

Quadrant	PF range	PF register range	PF formula
Quadrant 1	0 to +1	0 to +1	PF value = PF register value
Quadrant 2	-1 to 0	-2 to -1	PF value = (-2) - (PF register value)
Quadrant 3	0 to -1	-1 to 0	PF value = PF register value
Quadrant 4	+1 to 0	+1 to +2	PF value = (+2) - (PF register value)

For the configuration of PF Alarm there are four cases outline below

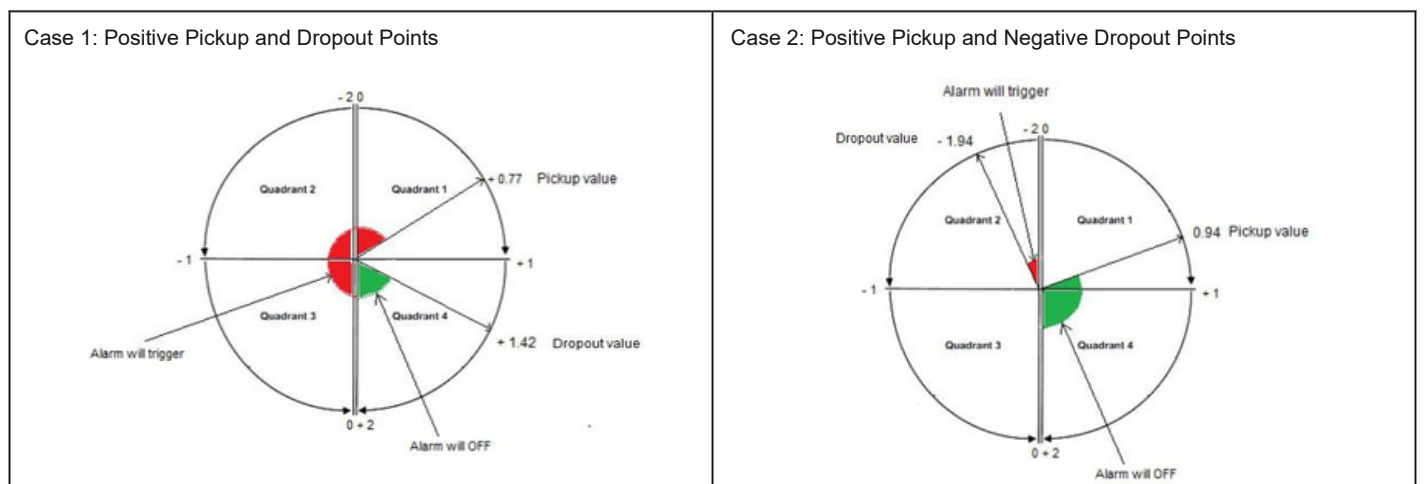

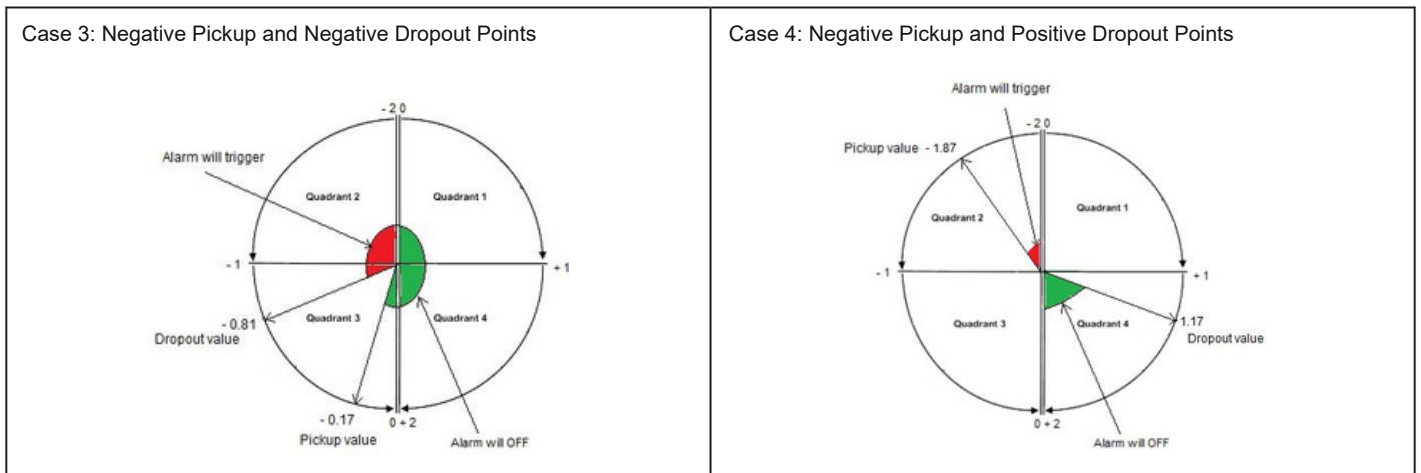

Alarm trigger condition:

- **Lagging power factor:** The alarm will trigger when the power factor (PF) value is less than both the pickup and dropout values. This indicates a significantly lagging power factor
- PF value < Pickup value AND PF value < Dropout value

Alarm deactivation condition:

- **Leading or Improved lagging power factor:** The alarm will deactivate when the power factor value is greater than both the pickup and dropout values. This indicates a leading or improved lagging power factor.
- PF value > Pickup value AND PF value > Dropout value

This means that both conditions must be true for the alarm to be off. If either condition is not met, the alarm will remain active

Note:

- **Red area:** This area signifies the region where the alarm will trigger. If the measured value falls within this red zone, the alarm system will activate.
- **Green area:** This area represents the region where the alarm will be off. If the measured value is within this green zone, the alarm system will remain inactive.

Phase loss alarm The phase loss alarm functions as an under setpoint alarm, designed to monitor the voltages within a three-phase system. It activates when one or two phases drop below the designated pickup setpoint and persist at that level for a duration sufficient to meet the pickup time delay requirement. Conversely, when all phases exceed the dropout setpoint and maintain that status long enough to fulfill the dropout time delay, the alarm condition is reset to OFF.

Alarm priorities:

Each alarm has a configurable priority level. Which are used distinguish between events that require immediate action and those that do not require action



Alarm priority	Alarm display notification and recording method				
	Alarm LED	Alarm display	Active Alarm with ACK	UNACK Alarm	Alarm history
High	Blinks while the alarm is active	Blinks while the alarm is active. "Alarm" remains displayed until Alarm is not off	All active alarm is display on active alarm page with ACK the alarm	UNACK alarm is display on UNACK ALARM page	Recorded in alarm history
Medium	Blinks while the alarm is active	Blinks while the alarm is active. "Alarm" remains displayed until Alarm is not off	All active alarm is display on active alarm page	UNACK alarm is display on UNACK ALARM page	Recorded in alarm history

Alarm priority	Alarm display notification and recording method				
	Alarm LED	Alarm display	Active Alarm with ACK	UNACK Alarm	Alarm history
Low	Blinks while the alarm is active	None	All active alarm is display on active alarm page	None	Recorded in alarm history
None	No activity	None	All active alarm is display on active alarm page	None	None



Note:

- The alarm LED notification only occurs if the alarm LED is configured for alarming
- If multiple alarms with different priorities are active at the same time, the display shows the alarms in the order they occurred

To acknowledge a high-priority alarm, follow these steps:

1. Long press (5 seconds) the 4th  key on the display to open the Active Alarms page
2. Press the 1st  key (ACK key) to acknowledge the alarm

If a dropout condition occurs before you can acknowledge the alarms:

1. Press the 4th  key (no long press required) to open the Unacknowledged Alarms page
2. Press the 1st  key (ACK button) to acknowledge each specific unacknowledged alarm listed on the page

Alarm setup overview

User can use the meter display or utility to configure unary, digital or standard alarms.

Binary alarm setup parameters

Parameters	Option or range	Description
ENABLE	0 – No (OFF) 1 – Yes (ON)	This enables or disables the alarm
PRIORITY	0 – NONE 1 – LOW 2 – MEDIUM 3 – HIGH	This sets the alarm priority and notification options
DIGITAL OUTPUT SELECTION	0-NONE 1-(INTERNAL) DO1 2-(INTERNAL) DO2	Select the outputs you want to control when the alarm is triggered
RELAY OUTPUT SELECTION	0-NONE 1-(EXTERNAL)RO1 2-(EXTERNAL)RO2 3-(EXTERNAL)RO3 4-(EXTERNAL)RO4	

Note: relay output selection is enable when connect external RO card and select RO CONTROL MODE as alarm

Digital alarm setup parameters

Configure the digital alarm setup parameters as required

Parameters	Option or range	Description
ENABLE	0 – No (OFF) 1 – Yes (ON)	This enables or disables the alarm
PICKUP_DELAY	0 to 999999	This specifies the number of seconds the digital input must be in the alarm pickup state before the alarm is tripped

Parameters	Option or range	Description
DROPOUT_DELAY	0 to 999999	This specifies the number of seconds the digital input must be out of the alarm pickup state before the alarm turns off
PRIORITY	0 – NONE 1 – LOW 2 – MEDIUM 3 – HIGH	This sets the alarm priority and notification options
DIGITAL OUTPUT SELECTION	0-NONE 1-(INTERNAL)DO1 2-(INTERNAL)DO2	Select the outputs you want to control when the alarm is triggered
RELAY OUTPUT SELECTION	0-NONE 1-(EXTERNAL)RO1 2-(EXTERNAL)RO2 3-(EXTERNAL)RO3 4-(EXTERNAL)RO4	

Standard alarm setup parameters

Configure the standard alarm setup parameters as required

Parameters	Option or range	Description
ENABLE	0 – No (OFF) 1 – Yes (ON)	This enables or disables the alarm
PICKUP	Varies depending on the standard alarm you are setting up	This is the value (magnitude) you define as the setpoint limit for triggering the alarm. For “over” conditions, this means the value has gone above the Pickup. For “under” conditions, this means the value has gone below the Pickup
PICKUP_DELAY	0 to 999999	This specifies the number of seconds the signal must stay above the pickup setpoint (for “over” conditions), or below the pickup setpoint (for “under” conditions) before the alarm is tripped
DROPOUT	Varies depending on the standard alarm you are setting up	This is the value (magnitude) you define as the limit for dropping out of the alarm condition. For “over” conditions, this means the value has gone below the Dropout. For “under” conditions, this means the value has gone above the Dropout
DROPOUT_DELAY	0 to 999999	This specifies the number of seconds the signal must stay below the dropout setpoint (for “over” conditions), or above the dropout setpoint (for “under” conditions) before the alarm condition is ended
PRIORITY	0 – NONE 1 – LOW 2 – MEDIUM 3 – HIGH	This sets the alarm priority and notification options
DIGITAL OUTPUT SELECTION	0-NONE 1-(INTERNAL) DO1 2-(INTERNAL) DO2	Select the outputs you want to control when the alarm is triggered.
RELAY OUTPUT SELECTION	0-NONE 1-(EXTERNAL)RO1 2-(EXTERNAL)RO2 3-(EXTERNAL)RO3 4-(EXTERNAL)RO4	

Parameters	Option or range	Description
PICKUP PF TYPE	0 – NONE 1 – INDUCTIVE 2 – CAPACITIVE	*Applies to PF (power factor) alarms only. Use this to set the PF value and quadrant to set the pickup setpoint for an over PF condition (PF Leading) or under PF condition (PF Lagging)
DROPOUT PF TYPE	0 – NONE 1 – INDUCTIVE 2 – CAPACITIVE	*Applies to PF (power factor) alarms only. Use this to set the PF value and quadrant to set the dropout setpoint for an over PF condition (PF Leading) or under PF condition (PF Lagging)

LED alarm indicator

When the LED CTRL MODE is set to "alarm," the LED blinks to signal an active alarm condition

Alarm history:

Meter stores the alarm history each time an alarm occurs. Each alarm is equipped with status, timer and counter function and the alarm history is stored in utility through Ethernet / RS485.

The alarm list holds up to 40 entries at a time. The history also works as a circular buffer, the list replaces old entries as the new entries arrive over 40 entries in the alarm event queue.

The alarm log shows the alarm history on modbus in following format:

- ALARM NAME
- EVENT TYPE
- DAY
- MONTH
- YEAR
- HOURS
- MINUTES
- SECONDS
- PHASE NO
- PHASE VALUE 0
- PHASE VALUE 1
- PHASE VALUE 2

DATA-LOGGING

• Data logs

Total 105 parameters are available for datalogging, of which up to 30 parameters can be data-logged at a time.

Data logging time can be configured from 1 to 1440 minutes(24hrs) using Relpol Utility

Meter provides 105 days of retention of the data-logs for 5 minute interval.

The data logging functionality of the meter offers users flexibility and efficiency in monitoring various parameters.

With a total of 105 parameters available for logging, users can tailor their monitoring needs by configuring up to 30 parameters at a time. Using Relpol Utility, users can easily adjust the logging time, spanning from a minimum of 1 minute to a maximum of 1440 minutes (equivalent to 24 hours). This granular control ensures that users can capture data at intervals that best suit their monitoring requirements, whether they need frequent updates or more long-term trend analysis. The meter ensures robust data retention, storing logs for up to 105 days at a 5-minute interval. This extensive retention period allows users to access historical data for extended periods, facilitating comprehensive analysis and troubleshooting.

Table of data retention time and time interval

Time interval (time scan) (minutes)	Data retention period (days)
1	21
5	105
10	213
30	640
60	1280
1440	30720

Memory allocations for data logs:

- Max. Records stored: 30720
- Max. register values recorded: 30
- Storage: 8 MB
- Parameter selection: All 105 parameters

Table of list of all 105 parameters

Sr no.	Parameters selection	Modbus addresses
1	Voltage V1N	44051
2	Voltage V2N	44052
3	Voltage V3N	44053
4	Average voltage LN	44055
5	Voltage V12N	44056
6	Voltage V23N	44057
7	Voltage V31N	44058
8	Average voltage LL	44059
9	Current L1	44060
10	Current L2	44061
11	Current L3	44062
12	Current N	44063
13	Average current	44065
14	Active power KW1	44066
15	Active power KW2	44067
16	Active power KW3	44068
17	Total active KW	44069
18	Apparent power KVA1	44070
19	Apparent power KVA2	44071
20	Apparent power KVA3	44072
21	Total apparent KVA	44073
22	Reactive power KVAR1	44074
23	Reactive power KVAR2	44075
24	Reactive power KVAR3	44076
25	Total reactive KVAR	44077
26	True power factor PH1	44078
27	True power factor PH2	44079
28	True power factor PH3	44080
29	True power factor total	44081
30	Frequency	44082
31	Mains energy active total IMP	44083
32	Mains energy active total EXP	44084
33	Mains energy active total NET	44085
34	Mains energy active total ABS	44086
35	Mains energy apparent total IMP	44087
36	Mains energy apparent total EXP	44088
37	Mains energy apparent total NET	44089
38	Mains energy apparent total ABS	44090
39	Mains energy reactive total IMP	44091

Sr no.	Parameters selection	Modbus addresses
40	Mains energy reactive total EXP	44092
41	Mains energy reactive total NET	44093
42	Mains energy reactive total ABS	44094
43	DG energy active total IMP	44095
44	DG energy active total EXP	44096
45	DG energy active total NET	44097
46	DG energy active total ABS	44098
47	DG energy apparent total IMP	44099
48	DG energy apparent total EXP	44100
49	DG energy apparent total NET	44101
50	DG energy apparent total ABS	44102
51	DG energy reactive total IMP	44103
52	DG energy reactive total EXP	44104
53	DG energy reactive total NET	44105
54	DG energy reactive total ABS	44106
55	Max DMD KW total	44107
56	Max DMD KVA total	44108
57	Max DMD KVAR total	44109
58	Min DMD KW total	44110
59	Min DMD KVAR total	44111
60	Present Max DMD KW total	44112
61	Present Max DMD KVA total	44113
62	Present Max DMD KVAR total	44114
63	Present Min DMD KW total	44115
64	Present Min DMD KVAR total	44116
65	Predictive Max DMD KW total	44117
66	Predictive Max DMD KVA total	44118
67	Predictive Max DMD KVAR total	44119
68	Predictive Min DMD KW total	44120
69	Predictive Min DMD KVAR total	44121
70	Last current DMD PH1	44122
71	Last current DMD PH2	44123
72	Last current DMD PH3	44124
73	Last current DMD AVG	44125
74	Present current DMD PH1	44126
75	Present current DMD PH2	44127
76	Present current DMD PH3	44128
77	Present current DMD AVG	44129
78	Predictive current DMD PH1	44130

Sr no.	Parameters selection	Modbus addresses
79	Predictive current DMD PH2	44131
80	Predictive current DMD PH3	44132
81	Predictive current DMD AVG	44133
82	Max current DMD PH1	44134
83	Max current DMD PH2	44135
84	Max current DMD PH3	44136
85	Max current DMD AVG	44137
86	DI 1	44138
87	DI 2	44139
88	DO 1	44140
89	DO 2	44141
90	External DI 1 count	44142
91	External DI 2 count	44143
92	Quadrant 1 KWH	44144
93	Quadrant 2 KWH	44145
94	Quadrant 3 KWH	44146
95	Quadrant 4 KWH	44147
96	Quadrant 1 KVAH	44148
97	Quadrant 2 KVAH	44149
98	Quadrant 3 KVAH	44150
99	Quadrant 4 KVAH	44151
100	Quadrant 1 KVARH	44152
101	Quadrant 2 KVARH	44153
102	Quadrant 3 KVARH	44154
103	Quadrant 4 KVARH	44155
104	Average THD voltage LN	44156
105	Average THD current	44157

Data logging process

1. Parameters selection for logging

- Available parameters: 105 (addresses 44051 to 44157 in holding registers)
- Maximum selectable parameters: 30

Steps:

1. Choose any 30 parameters from the holding register range 44051 to 44157
2. Configure these parameters for logging

2. Time interval configuration

- Intervalrange:
 - Minimum: 1 minute
 - Maximum: 1440 minutes (24 hours)
- Steps:

Write the desired logging time interval (in minutes) to holding register 44306

3. Start / Stop data logging

- Tostartlogging:

Write 1 to holding register 44305
- To stop logging:

Write 0 to holding register 44305

4. Retrieve logged data

- Totalrecords:30,720
- Steps to retrieve:
 1. Pass the desired record number to holding register 44179
 2. Read data from holding registers 44182 to 44301 for the selected parameters
 3. Each parameter occupies 8 bytes

5. Additional information

- Get record data:
 - Record number: read from holding register 44302
 - Overwrite counter: read from holding register 44303
 - Timestamp: read from holding register 44180
- Error status:
- Read from: holding register 44307

Values:

- 128: No error
- 1: CRC error
- 2: Read error
- 4: Write error
- 8: Erase error

INPUTS / OUTPUTS

Inputs / Outputs

Available I/O ports

The meter is equipped with digital inputs, digital outputs and relay outputs.

- The meter has 2 digital inputs and 2 digital output, after wiring the I/O ports they can be configured using communication

Digital inputs:

- The meter is equipped with 2 digital input ports (DI1, DI2). The digital inputs can be configured based on the application required.
- The DI requires external voltage to detect on/off state, if the external voltage appearing on the DI is within the operating range
- (24-48V DC) the meter detects ON state.

***Note:** DI1 is fixed for DG

Digital input connection

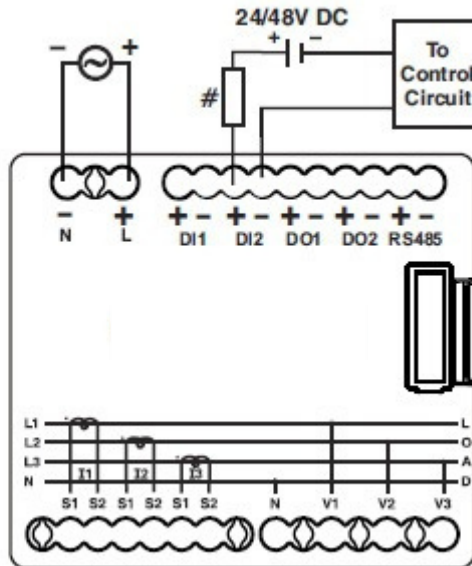

Digital outputs:

- The meter is equipped with 2 digital output ports, which are configurable based on the application. Example energy Pulsing, Demand synchronization, Switching application etc.

Digital output connection

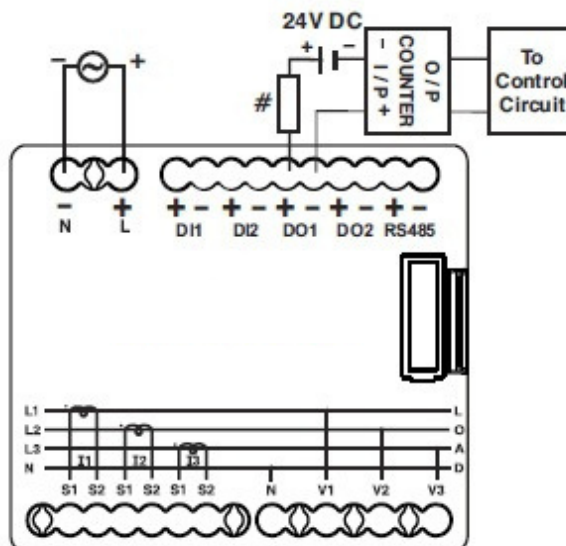

Configure the INTERNAL (2 DI: 2 DO) IO setup parameters as required

Parameters	Option or range	Description
DI CONTROL MODE	0 – NONE 1 – NORMAL 2 – DEMAND	This field displays how the status input functions. None: "None: The digital input is not associated with another meter function. The meter does not count or record incoming pulses." Normal: the digital input is not associated with another meter function. The meter counts and records the number of incoming pulses normally. Demand: the status input is associated with one of the input demand functions. The meter uses the incoming pulse to synchronize its demand period with the external source.
DI DEBOUNCE TIME (ms)	1 to 9999	Debounce is the time delay that compensates for mechanical contact bounce. Use this field to set how long (in milliseconds) the external signal must remain in a certain state to be considered a valid state change.
DO CONTROL MODE	0 – NONE 1 – ENERGY PULSES 2 – EXTERNAL 3 – DEMAND 4 – ALARM	This field displays how the digital output functions. <ul style="list-style-type: none"> • None: The digital output is not associated with any system. • Energy pulses: The digital output is associated with energy pulsing. When this mode is selected, you can select the energy parameter and set pulse rate (p/k_h). • External: The digital output is controlled remotely either through software or by a PLC using commands sent through communications. • Demand: the digital output is associated with one of the demand systems. The meter sends a pulse to the digital output port at the end of every demand interval. • Alarm: The digital output is associated with the alarm system. The meter sends a pulse to the digital output port when the alarm is triggered.
DO BEHAVIOUR MODE	0 – NORMAL 1 – TIMED 2 – COIL HOLD	<ul style="list-style-type: none"> • Normal: This mode applies when control mode is set to External or Alarm. In the event of trigger for external mode, the digital output remains in the ON state until an OFF command is sent by the computer or PLC. In the event of trigger for alarm mode, the digital output remains in the ON state until the drop out point is crossed. • Timed: The digital output remains ON for the period defined by the On time setup register. • Coil hold: This mode applies when control mode is set to External or Alarm. For a unary alarm that is associated with a digital output, you must set behavior mode to coil hold. The output turns on when the "energize" command is received and turns off when the "coil hold release" command is received. In the event of a control power loss, the output remembers and returns to the state it was in when control power was lost.
DO ON TIME (secs)	1 to 9999	This setting defines the pulse width (ON time) in seconds
DO INTERNAL COMMAND	0 – LOW 1 – HIGH	<p>Low: a low signal on the input de-asserts the digital output, leading to device deactivation.</p> <p>High: A high signal, on the other hand, asserts the digital output, resulting in device activation.</p> <p>Note: DO internal command option is selectable when DO control mode type is external.</p>

The meter consist of an I/O expansion module for the purpose of increasing Digital inputs, and Relay output. The available external I/O can be configured for 2DI+4RO.

The extended I/O is configured using meter front panel or communication

• **Digital inputs(DI):**

The meter external I/O can be set to digital input ports(DI). Those digital Inputs can be configured based on the application required

The DI requires external voltage to detect ON/OFF state, if the external voltage appearing on the DI is within the operating range(24 - 48V DC) the meter detects ON state

• **Relay output (RO):**

• The meter external IO can be set to form a mechanical relay output. Those relay outputs can be configured to used switching applications, for example, to provide ON/OFF control signals for switching capacitor banks, generators, and other external devices and equipment

DI & RO connection

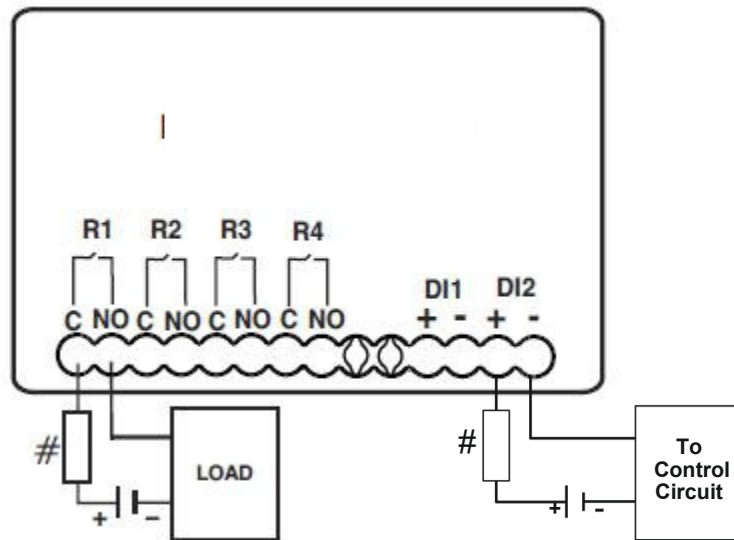

NOTE: Unexpected change of state of the relay outputs may result when the supply power to the meter is interrupted or after a meter firmware upgrade.

Configure the EXTERNAL(DI,DO,RO) IO setup parameters as required

Parameters	Option or range	Description
DI CONTROL MODE	0 – NONE 1 – NORMAL 3 – TARIFF	This field displays how the digital input functions. None: The input is not associated with another meter function. The meter does not count or record incoming pulses." Normal: the digital input is not associated with another meter function. The meter counts and records the number of incoming pulses normally. Tariff: The digital input is associated with one of the Tariff. The meter counts and records the number of incoming pulses and related consumption data associated with the pulses
DI DEBOUNCE TIME (ms)	10 to 9999	Debounce is the time delay that compensates for mechanical contact bounce. Use this field to set how long (in milliseconds) the external signal must remain in a certain state to be considered a valid state change
RO CONTROL MODE	0 – NONE 1 – ALARM 2 – EXTERNAL	This field displays how the relay output functions. <ul style="list-style-type: none"> • None: The relay output is not associated with any system. • Alarm: the relay output is associated with the alarm system. The meter sends a pulse to the relay output port when the alarm is triggered. • External: the relay output is controlled remotely either through software or by a PLC using commands sent through communications
RO BEHAVIOUR MODE	0 – NORMAL 1 – TIMED 2 – COIL HOLD	<ul style="list-style-type: none"> • Normal: This mode applies when control mode is set to External or Alarm. In the event of trigger for external mode, the relay output remains in the closed state until an open command is sent by the computer or PLC. In the event of trigger for Alarm mode, the relay output remains in the closed state until the drop out point is crossed. • Timed: The relay output remains ON for the period defined by the On time setup register • Coil hold: This mode applies when control mode is set to External or Alarm. For a unary alarm that is associated with a relay output, you must set Behavior mode to coil Hold. The output turns on when the “energize” command is received and turns off when the “coil hold release” command is received. In the event of a control power loss, the output remembers and returns to the state it was in when control power was lost
RO ON TIME (secs)	1 to 9999	This setting defines the pulse width (ON time) in seconds

RTD

- **RTD** The meter is equipped with a RTD module for the purpose of measurement of surrounding temperature. The meter seamlessly accepts standard RTD inputs and accurately linearizes them into temperature readings, ensuring precise monitoring of various temperature ranges. Its full 4-digit display provides ample space to showcase a broad spectrum of temperature inputs with clarity and accuracy. Users can view between Fahrenheit and Celsius on Utility and MODBUS for their preferred unit of measurement.

RTD sensor:

- **SENSOR TYPE:** PT100
- **TYPE OF INPUT:** DIFFERENTIAL
- **RESOLUTION:** 0.1 °C

- **DIGITAL RESOLUTION:** 12-bit
- **ANALOG INPUT ERROR AT 25 °C:** $\pm 0.25\%$ of full scale,
- **NON-LINEARITY:** $\pm 0.25\%$ OF full scale
- **CONVERSION TIME:** $< 100\text{ms}$
- **CHANNEL ISOLATION:** NO
- **INPUT ISOLATION FROM UNIT MAIN MODULE:** YES
- **UNDER RANGE VALUE:** $> -150\text{ }^{\circ}\text{C}$
- **OVER RANGE VALUE:** $< 850\text{ }^{\circ}\text{C}$
- **PROTECTION AGAINST POLARITY INVERSION:** YES

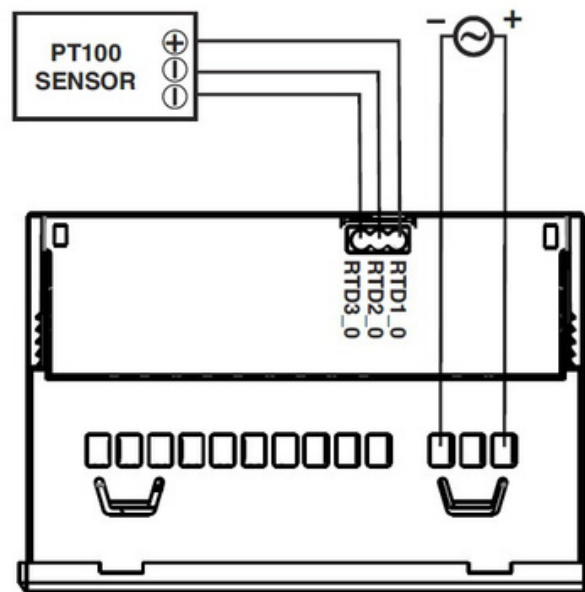



RTD connections:

FIRMWARE UPGRADE

The meter supports on-site firmware upgrades for adding new functionality to the meter using separate downloader software.

Procedure for firmware upgradation.

1. Go to www.relpol.com.pl to download the separate downloader-software for RMM-683.
2. Download the newly uploaded firmware file (extension is XYZ.bin) from www.relpol.com.pl
3. Connect the meter to PC through RS485 communication.
4. Open separate downloader.
5. Check the communication setting of meter has properly select in downloader utility.
6. Select the COM port of PC
7. Browse the firmware saved location path from your PC.
8. Select bin file and then click - open
9. Press  +  key of meter then powered UP the meter and then release the key.
10. Meter will enter in boot loader mode, on display it will show "BOOT"
11. Click on download to download the upgraded firmware into; meter.
12. Downloading will start and meter will show the current downloading progress (in percent complete up to 100%) on display panel;
13. When the firmware upgrade is complete, separate downloader will show "download of bin file is successful".
14. After downloading the firmware, the meter will restart automatically.
15. Check the upgraded firmware version number under self-test mode

Note: One meter can be upgrade at a one time from same PC.

Separate downloader is a program by the software third party company.

Entry of boot loader mode can be accessed via communication or from the meter front.